

R-1480

Instruções de Montagem Assembly Instructions Instrucciones de Armado

Acesse Vídeos de Montagens
Access Mounting Videos
Acceder a los Vídeos de Montaje
www.tecnomobili.ind.br

tecnomobili

Estrada RSC 453, Km s/n° | Garibaldi | RS
CEP: 95720-000 | Fone / Fax: 54.3464.2050
sac@moveisvideira.com.br

Lista de Peças / List of pieces / Lista de piezas

CÓD	DESCRIÇÃO	DESCRIPTION	DESCRIPCIÓN	QTD	RAW MATERIAL	DIMENSION	CÓD
01	Lateral Direita	Right Side	Lateral Derecha	1	MDP 15mm	450x325x15mm	301480
02	Prateleira	Shelf	Entrepanõs	1	MDP 15mm	792x293x15mm	201480
03	Divisão	Division	División	1	MDP 15mm	450x309x15mm	501480
04	Base	Base	Base	1	MDP 15mm	1600x325x15mm	101480
05	Lateral Esquerda	Left Side	Lateral Izquierda	1	MDP 15mm	450x325x15mm	311480
06	Rodapé Frontal	Front Baseboard	Rodapie Frontal	1	MDP 15mm	1520x132x15mm	801480
07	Aplik Rodapé	Aplik Baseboard	Aplik Rodapie	3	MDP 15mm	1518x25x15mm	851480
08	Rodapé Menor	Botton Baseboard	Rodapie Menor	4	MDP 15mm	270x132x15mm	801479
09	Rodapé Traseiro	Back Baseboard	Rodapie Trasero	1	MDP 15mm	1520x132x15mm	811480
10	Travessa	Traverse	Traviessa	6	MDP 15mm	450x45x15mm	601480
11	Tampo	Top	Tapa	1	MDP 15mm	1600x325x15mm	701480
12	Travessa Pega	Touch Traverse	Traviessa de Toque	1	MDP 15mm	761x45x15mm	611480
13	Costa	Back	Costa	2	MDF 3mm	779x236x3mm	401480
14	Costa Maior	Larger Back	Costa Maior	1	MDF 3mm	812x236x3mm	411480
15	Porta	Door	Puerta	2	MDP 15mm	384x422x15mm	81480

Notas Especiais:

01 -Examine completamente todas as peças do móvel antes de começar o trabalho.

02 -Recomenda-se montar o móvel conforme este Manual de Montagem.

03 -É de responsabilidade do montador seguir as instruções do Manual de Montagem, que são fundamentais para garantir a estrutura do móvel.

04 -Para limpeza, utilizar somente pano úmido e sabão neutro.

Special notes:

01 -Check all parts of the unit thoroughly before starting work.

02 -It is recommended to assemble the furniture according to this Installation Manual.

03 -It is the responsibility of the assembler to follow the instructions in the Assembly Manual, which are essential to ensure the structure of the furniture.

04 -For cleaning use only damp cloth and neutral soap.

Notas especiales:

01 -Examine completamente todas las piezas del mueble antes de iniciar el trabajo.

02 -Se recomienda montar el mueble conforme el Manual de Ensamblaje.

03 -Es de responsabilidad del montador seguir las instrucciones del Manual de Ensamblaje, que son fundamentales para garantizar la estructura del mueble.

04 -Para limpieza solamente usar trapo húmedo y jabón neutro.

Guarante certificate:



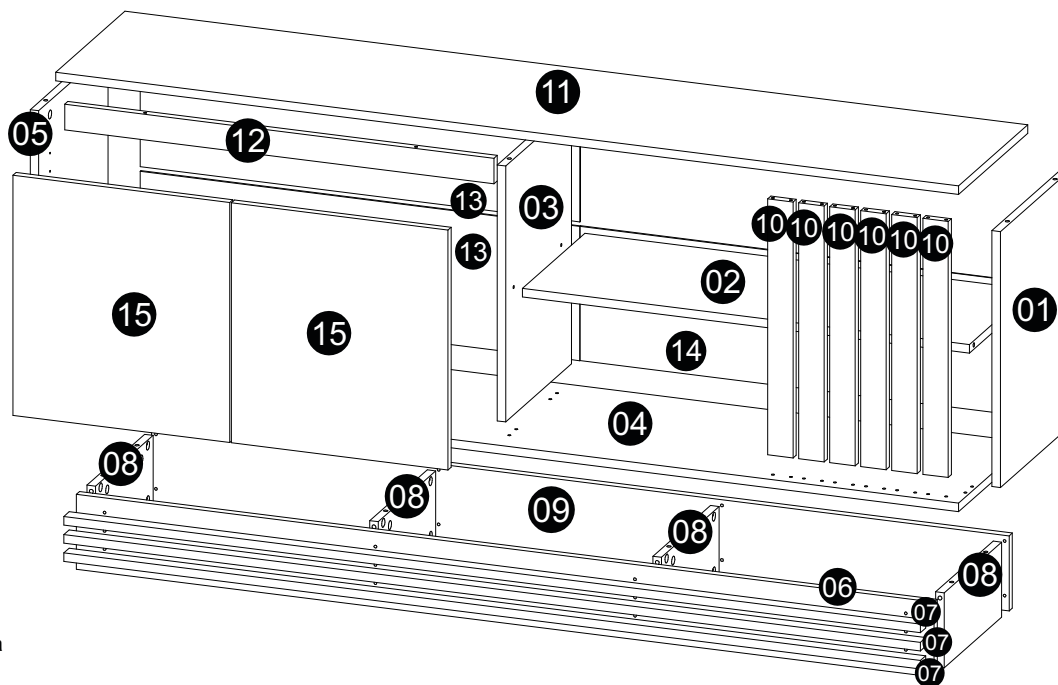





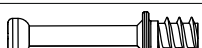

The guarantee of products manufactured by Móveis Videira LTDA covers any defects / manufacturing defects, within the period established by the Consumer Protection Code, in its Article 26, II, which provides for a legal guarantee of ninety (90) days.



TAMANHO REAL - TAMAÑO VERDADERO - REAL SIZE

REF	DESCRIÇÃO	QTD	cód
A	 Parafuso 3,5 x 40mm CC	08	8115
B	 3,5 x 14mm CC	16	3639
C	 Cavilha 5 x 30mm	30	3880

ILUSTRAÇÃO - ILLUSTRATION

REF	DESCRIÇÃO	QTD	cód
D	 34 x 7mm Parafuso Minifix	34	3771
E	 15 x 12mm Tambor Minifix	34	9516
F	 22 x 3mm Prego 10x10	55	3051
G	 14 x 4mm Sapata Deslizadora	08	8112
H	 Adesivo Tapa Furo	02	
I	 Suporte Prateleira 8x10	02	3748
J	 Dobradiça Reta 26mm Calço n° 1	02	3614
K	 Dobradiça Curva 26mm Calço n° 12	02	6517
L	 Perfil I 761 mm	01	
M	 3,5x30mm CP	12	9517
N	 13 x 13 x 3mm Fixador de Costa	02	6524

Ferramentas | Tools | Herramientas

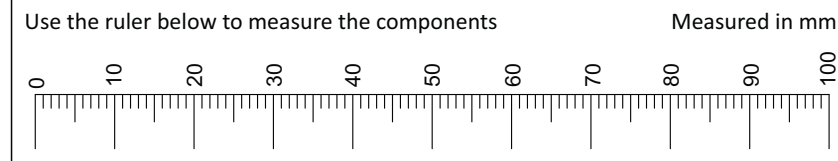
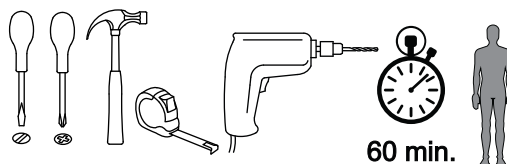

1

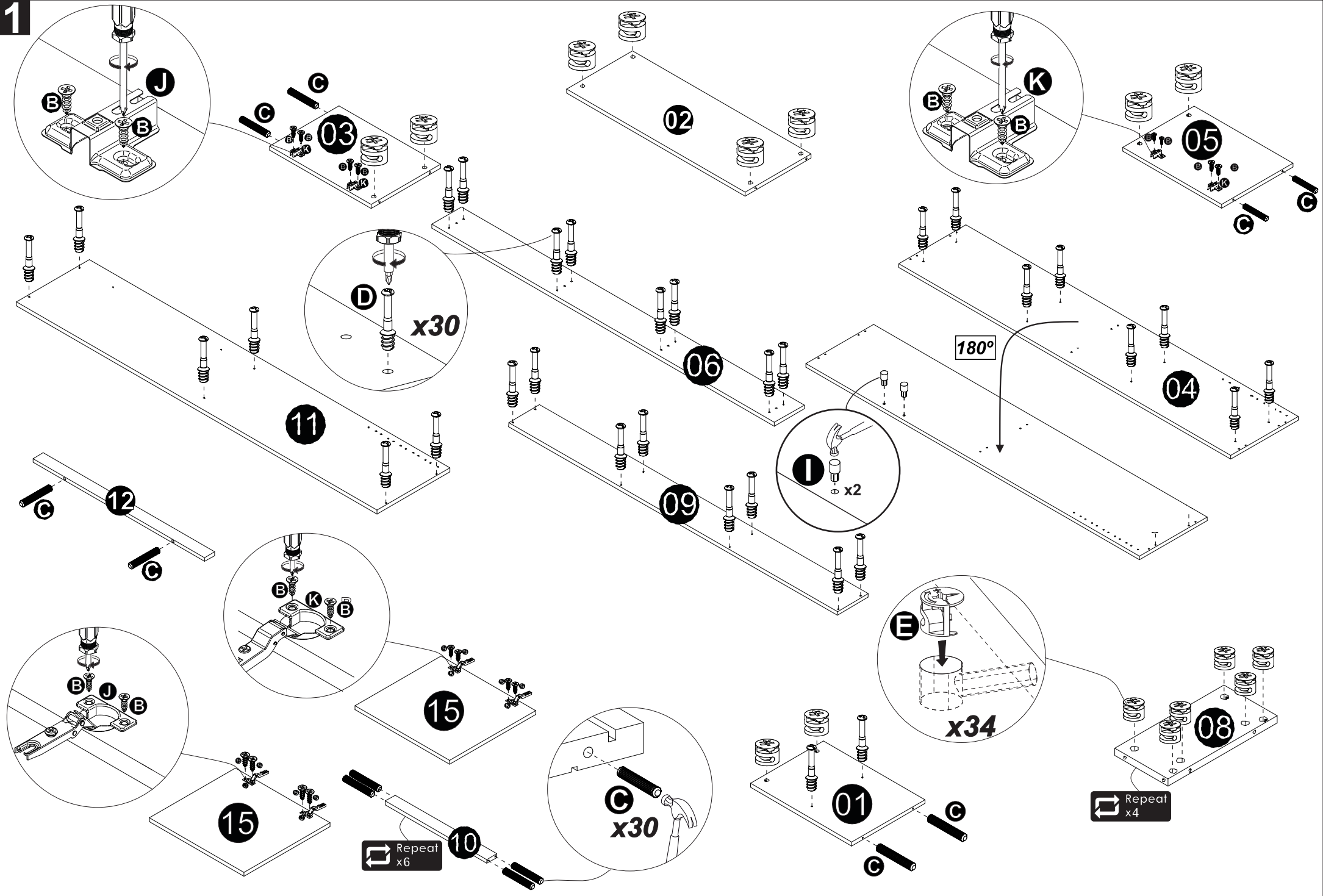

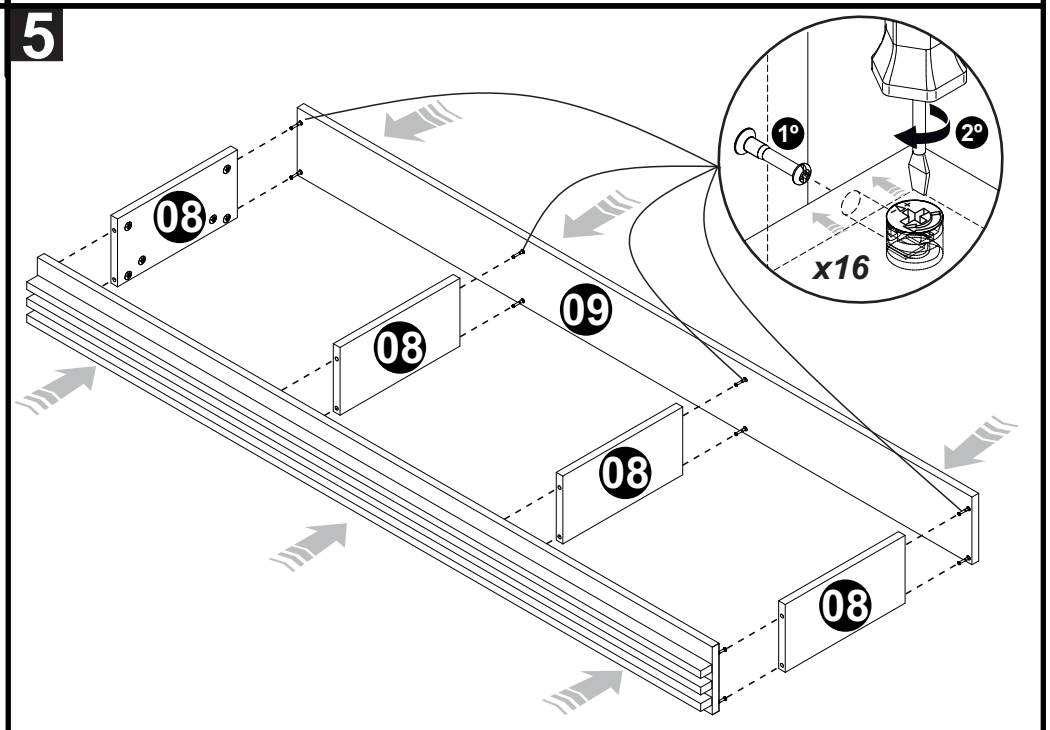
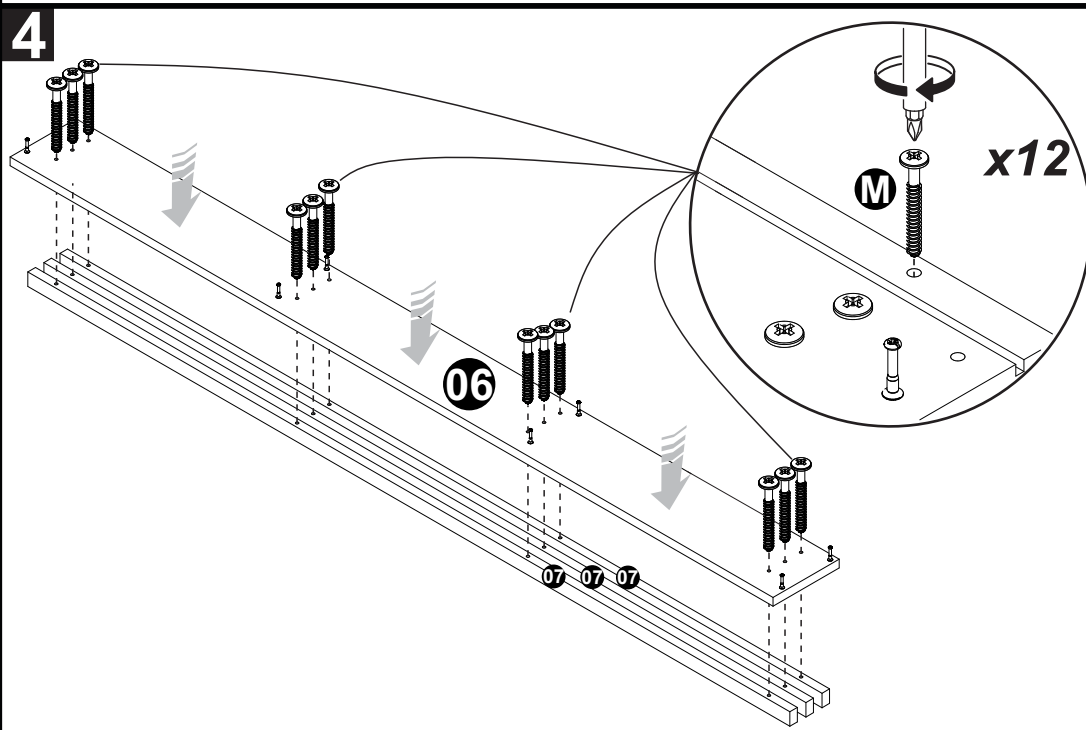
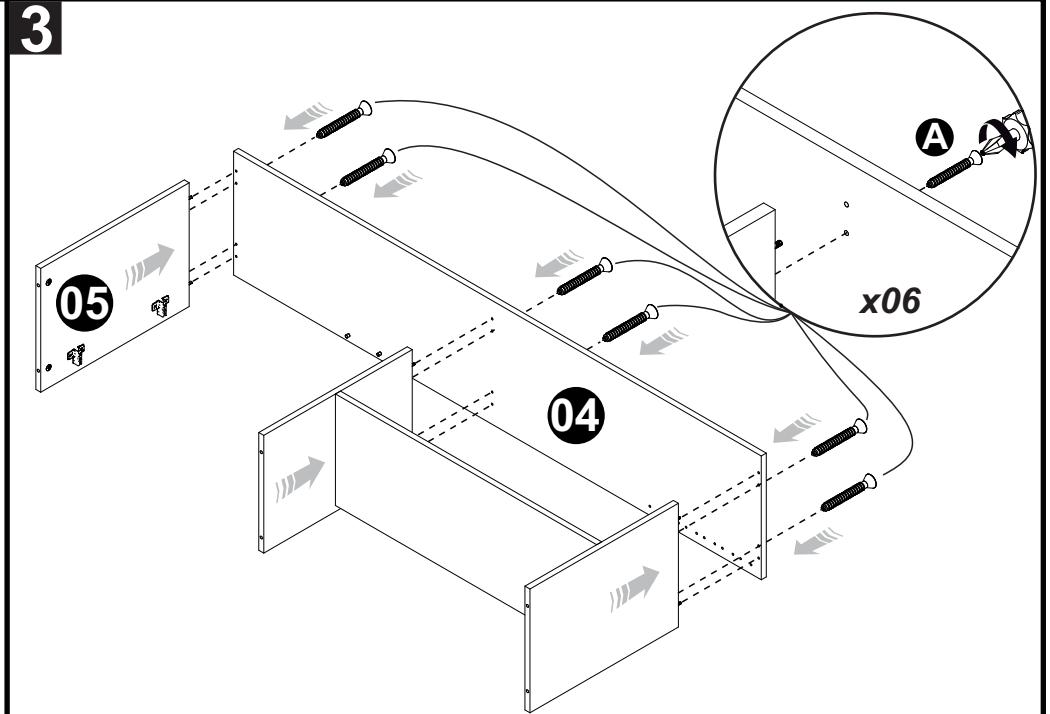
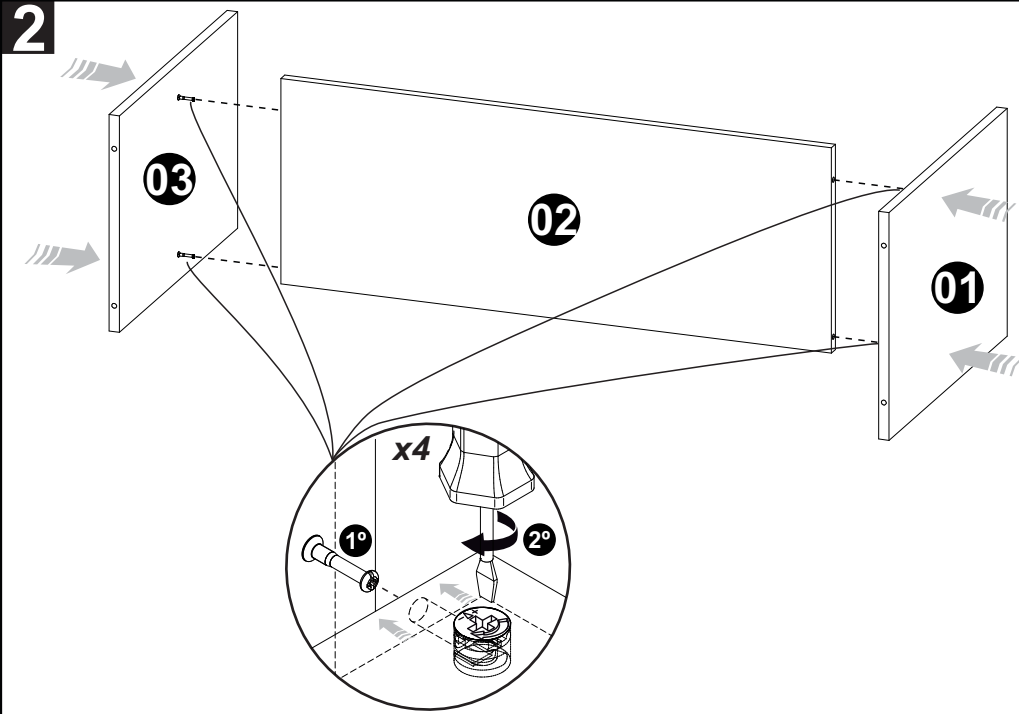

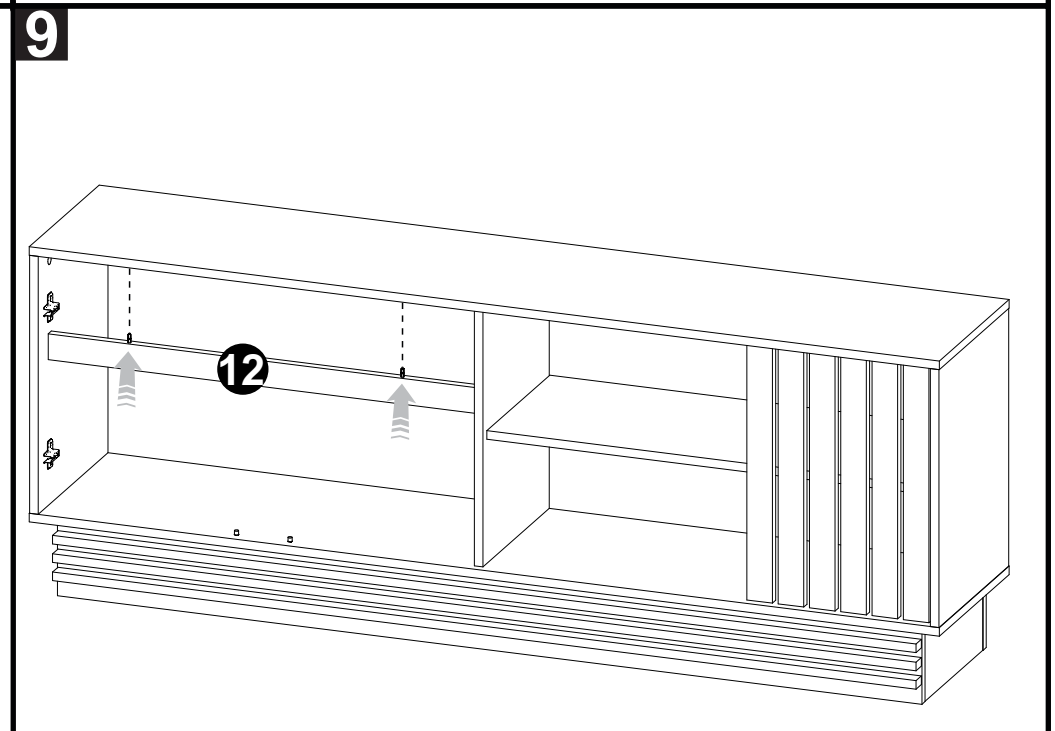
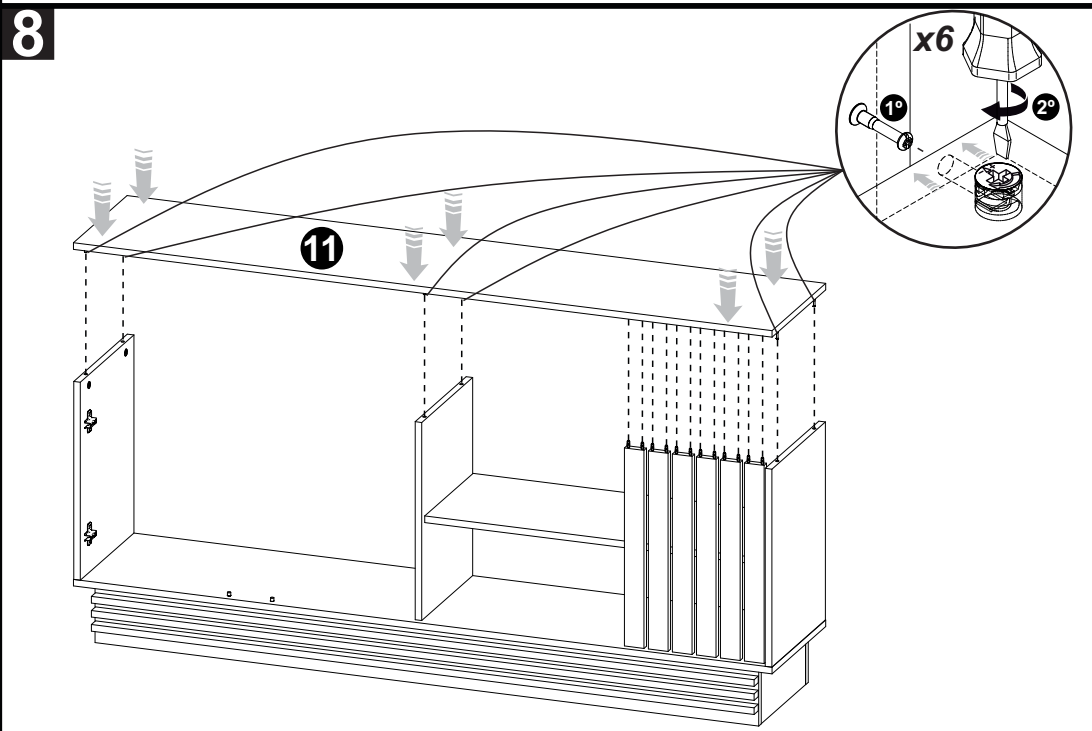
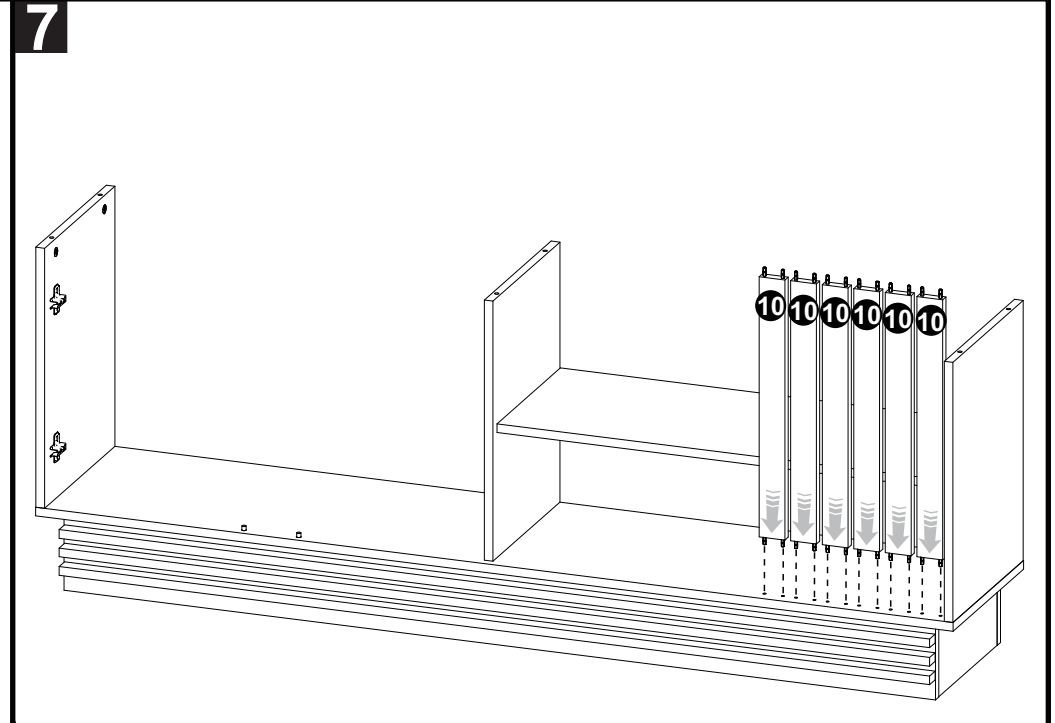
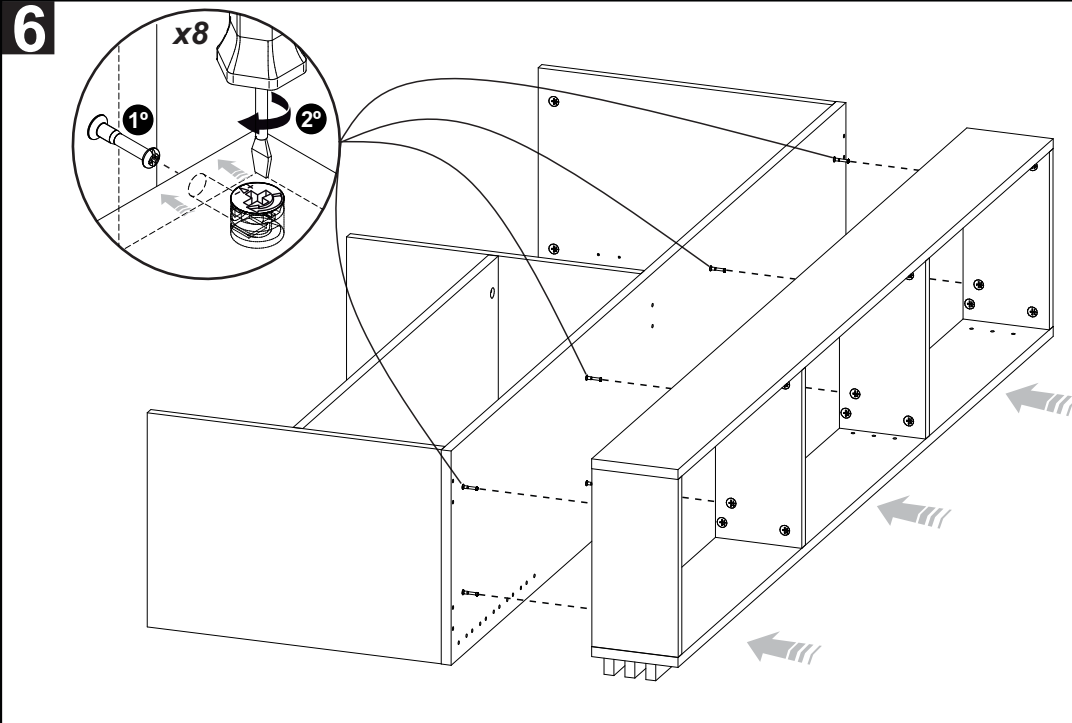

10

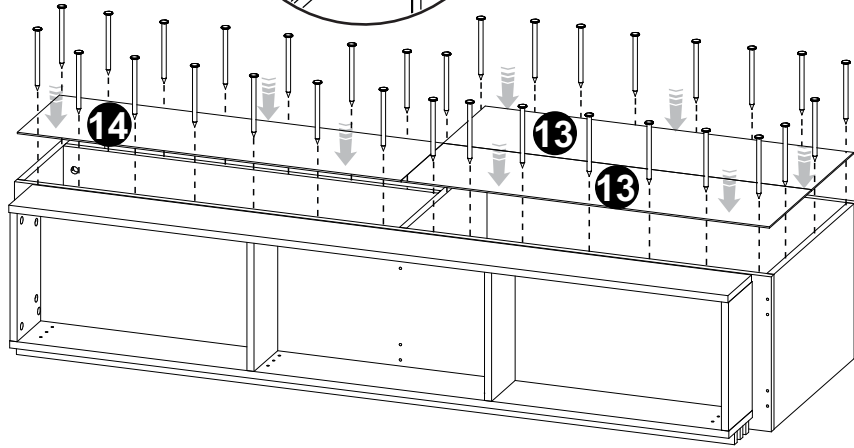
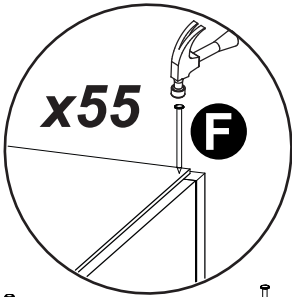

11

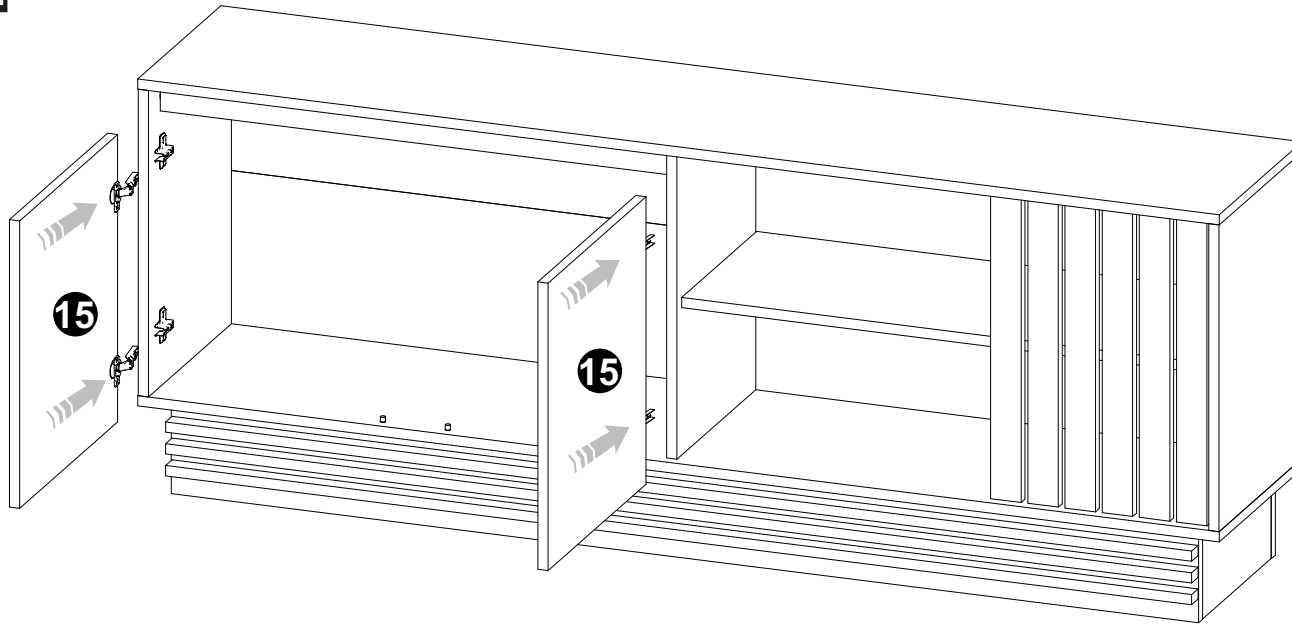

Colocar a dobradiça sobre o calço. / Place the hinge on the wedge. / Colocar la bisagra sobre el calzo.

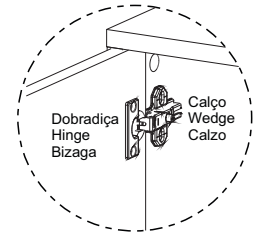

Ajuste das Portas- Ajustes de las Puertas- Doors Adjustment

