

CM-8037

Instruções de Montagem Assembly Instructions Instrucciones de Armado

Acesse Vídeos de Montagens
Access Mounting Videos
Acceder a los Vídeos de Montaje
www.tecnomobili.ind.br

tecnomobili

Estrada RSC 453, Km s/n° | Garibaldi | RS
CEP: 95720-000 | Fone / Fax: 54.3464.2050
sac@moveisvideira.com.br

Notas Especiais:

- 01** -Examine completamente todas as peças do móvel antes de começar o trabalho.
02 -Recomenda-se montar o móvel conforme este Manual de Montagem.
03 -É de responsabilidade do montador seguir as instruções do Manual de Montagem, que são fundamentais para garantir a estrutura do móvel.
04 -Para limpeza, utilizar somente pano úmido e sabão neutro.

Special notes:

- 01** -Check all parts of the unit thoroughly before starting work.
02 -It is recommended to assemble the furniture according to this Installation Manual.
03 -It is the responsibility of the assembler to follow the instructions in the Assembly Manual, which are essential to ensure the structure of the furniture.
04 -For cleaning use only damp cloth and neutral soap.

Notas especiales:

- 01** -Examine completamente todas las piezas del mueble antes de iniciar el trabajo.
02 -Se recomienda montar el mueble conforme el Manual de Ensamblaje.
03 -Es de responsabilidad del montador seguir las instrucciones del Manual de Ensamblaje, que son fundamentales para garantizar la estructura del mueble.
04 -Para limpieza solamente usar trapo húmedo y jabón neutro.









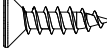
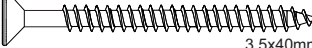
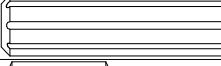
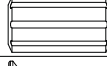
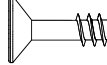
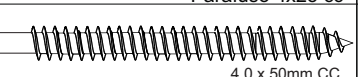

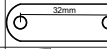

Guarante certificate:

The guarantee of products manufactured by Móveis Videira LTDA covers any defects / manufacturing defects, within the period established by the Consumer Protection Code, in its Article 26, II, which provides for a legal guarantee of ninety (90) days.

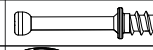
Lista de Peças / List of pieces / Lista de piezas

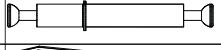
CÓD	DESCRIÇÃO	DESCRIPTION	DESCRIPCIÓN	QTD	M. PRIMA	DIMENSÕES	CÓD
01	Divisão Esquerda	Left Division	División Izquierda	1	MDP 15 mm	934x350x15 mm	518037
02	Costa	Back	Costa	2	MDP 15 mm	623x350x15 mm	408037
03	Travessa Pega	Platter Catches	Traviesa Pega	1	MDP 15 mm	623x65x15 mm	638037
04	Divisão Direita	Right Division	División Derecha	1	MDP 15 mm	934x350x15 mm	508037
05	Rodapé	Baseboard	Rodapie	2	MDP 15 mm	1900x65x15 mm	808037
06	Base Traseira	Back Base	Base Trasera	1	MDP 15 mm	1900x467x15 mm	118037
07	Base Frontal	Front Base	Base Frontal	1	MDP 15 mm	1900x467x15 mm	108037
08	Peseira Direita	Right Weight	Pesera Derecha	1	MDP 15 mm	525x92x15 mm	338037
09	Peseira Esquerda	Left Weight	Pesera Derecha	1	MDP 15 mm	525x92x15 mm	348037
10	Travessa Inferior Peseira	Headrest Botton Traverse	Traviesa Inferior Pesera	1	MDP 15 mm	756x80x15 mm	628037
11	Cabeceira	Headboard	Cabecera	1	MDP 15 mm	810x120x15 mm	708037
12	Travessa Ripado	Traverse	Traverse	6	MDP 15 mm	160x65x15 mm	608006
13	Cabeceira Intermediaria	Interdiate Headboard	Cabecera Intermediaria	1	MDP 15 mm	810x389x15 mm	718037
14	Cabeceira Inferior	Lower Headboard	Cabecera Inferior	1	MDP 15 mm	810x389x15 mm	728037
15	Pé Cabeceira Direito	Right Foot Headboard	Pie Derecho Cabecera	1	MDP 15 mm	1060x65x15 mm	318037
16	Pé Cabeceira Esquerdo	Left Foot Headboard	Pie Izquierdo Cabecera	1	MDP 15 mm	1060x65x15 mm	328037
17	Travessa Cabeceira	Headboard Traverse	Traviesa Cabecera	1	MDP 15 mm	942x45x15 mm	618037
18	Travessa Superior Peseira	Headrest Upper Traverse	Traviesa Superior Pesera	1	MDP 15 mm	904x92x15 mm	608037
19	Lateral	Side	Lateral	2	MDP 15 mm	1900x92x15 mm	308037
20	Suporte Para Lastro	Ballast Suport	Soporte Lastre	4	MDP 22 mm	900x42x22 mm	9697
21	Lastro	Ballast	Lastre	12	MDP 10 mm	900x70x10 mm	9543
22	Porta	Door	Puerta	1	MDP 15 mm	616x325x15 mm	88037

TAMANHO REAL - TAMAÑO VERDADERO - REAL SIZE			
REF	DESCRIÇÃO	QTD	CÓD
A	 3,5x14mm CC	44	3639
B	 3,5x40mm CC	08	8115
C	 Cavilha 8 x 30mm	58	2806
D	 Cavilha 8 x 20mm	02	6521
E	 Parafuso 4x25 cc	04	9511
F	 4,0 x 50mm CC	16	9779

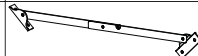
LUSTRAÇÃO - ILUSTRACION - ILLUSTRATION			
REF	DESCRIÇÃO	QTD	CÓD
G	 22x3mm Pregos 10x10	38	3051
H	 OU  22x17x12mm	03	3572
I	 14 x 4mm Sapata Deslizadora	14	8112
J	 Dobradiça Alta 26mm Calço N° 12	02	6517
K	 32mm Chapa Metálica 42x14x1,2mm	02	8889
L	 9 x 12mm Porca Cilíndrica	08	9449
M	 34x7mm Parafuso minifix	14	3771
N	 15x12mm Tambor minifix	34	9516
O	 Adesivo Tapa Furo	20	
P	 62 x 7mm Minifix Haste Dupla	10	8991
Q	 25,6 x 40mm Suporte para Lastro	08	
R	 Parafuso 3,5 x 14 CF	14	3639
S	 12 x 12 x 12mm Cantoneira 2 Furos	14	3615
T	 325 x 48 x 17mm Articulador c/Trava Esquerdo	01	9608



Ferramentas | Tools | Herramientas

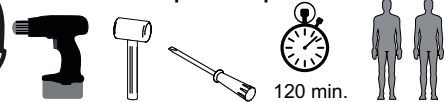

120 min.

Revisão: 00
Data: 27/06/2023

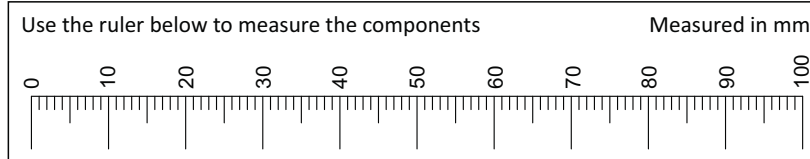

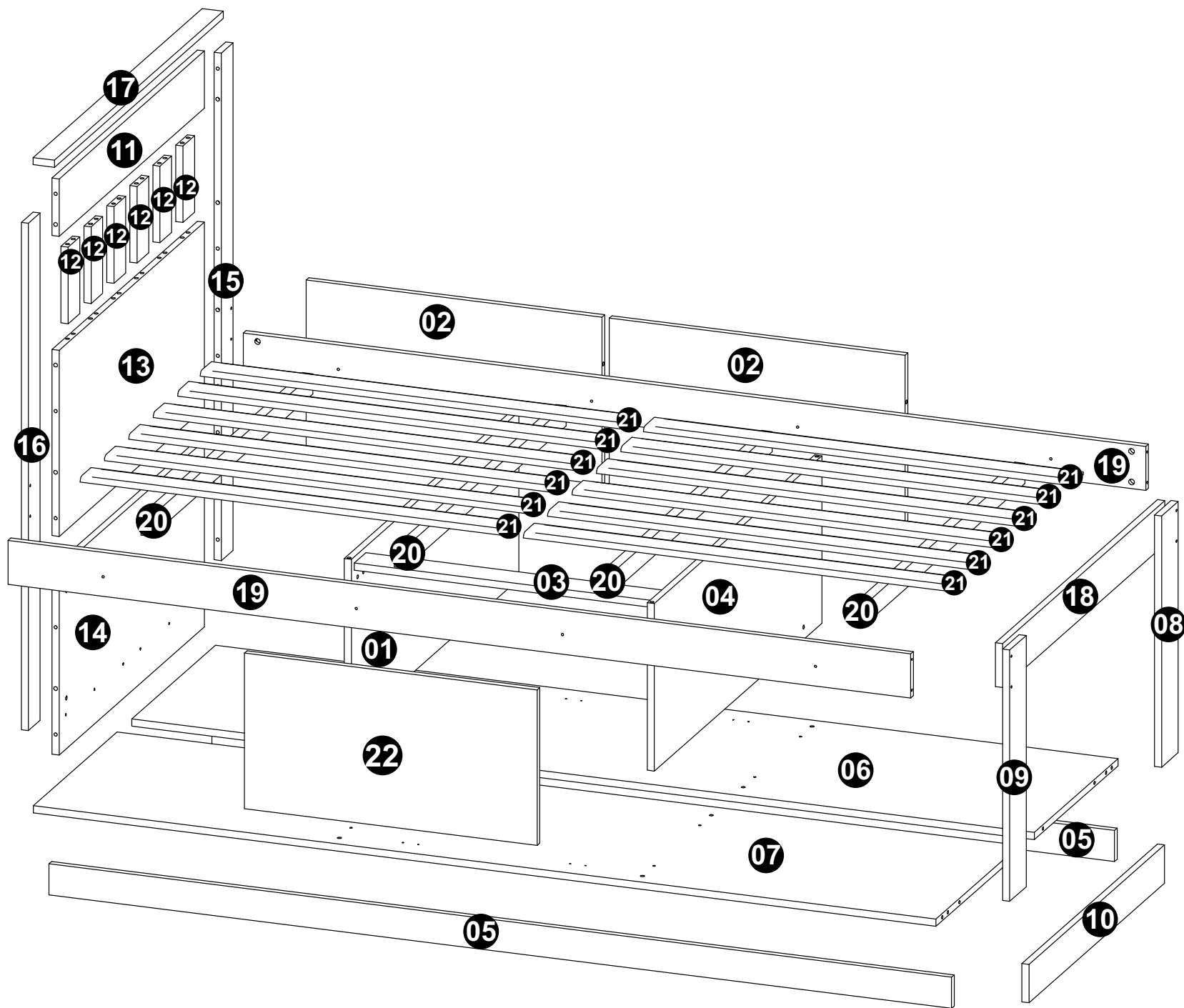

2

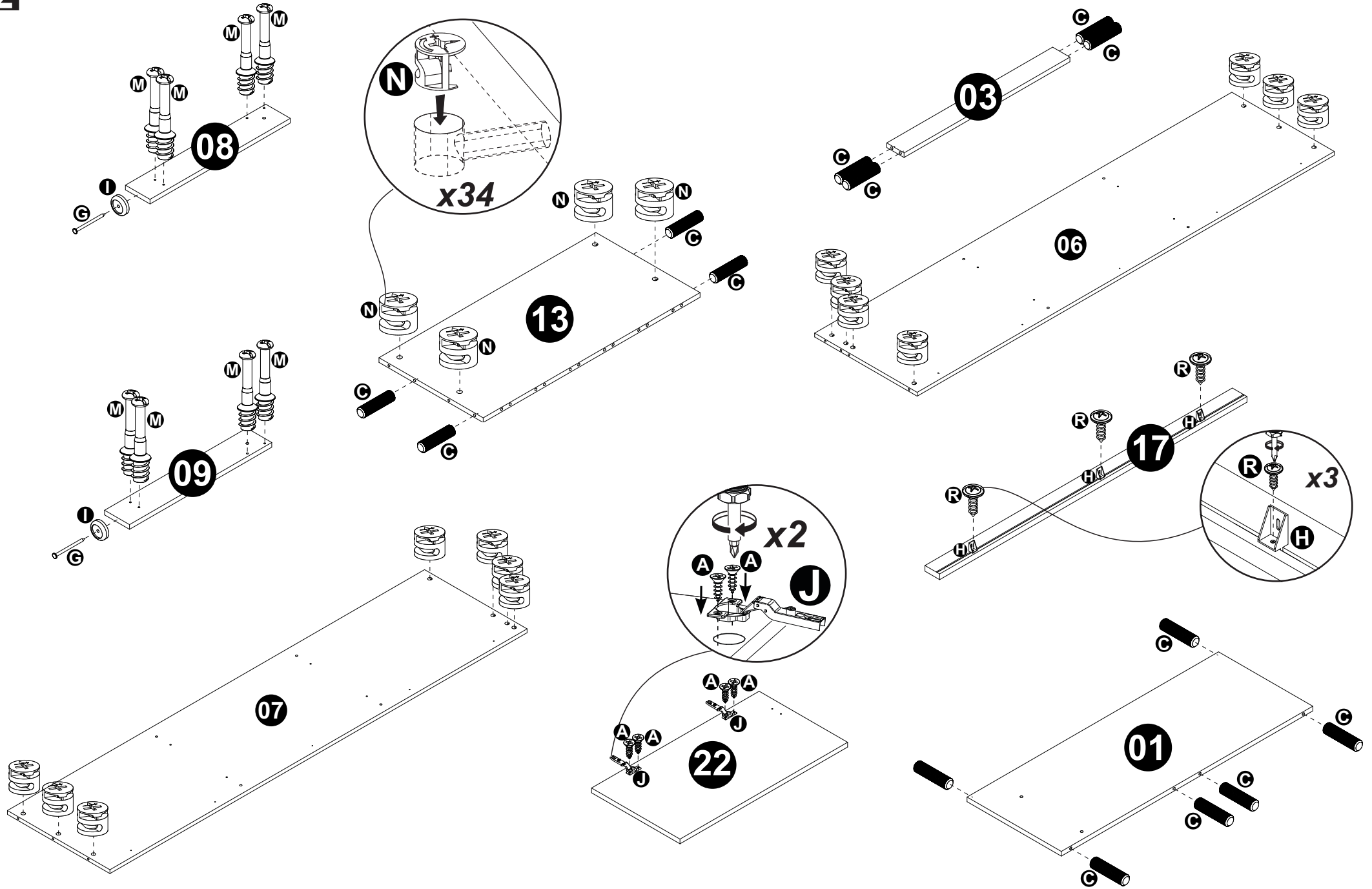

3

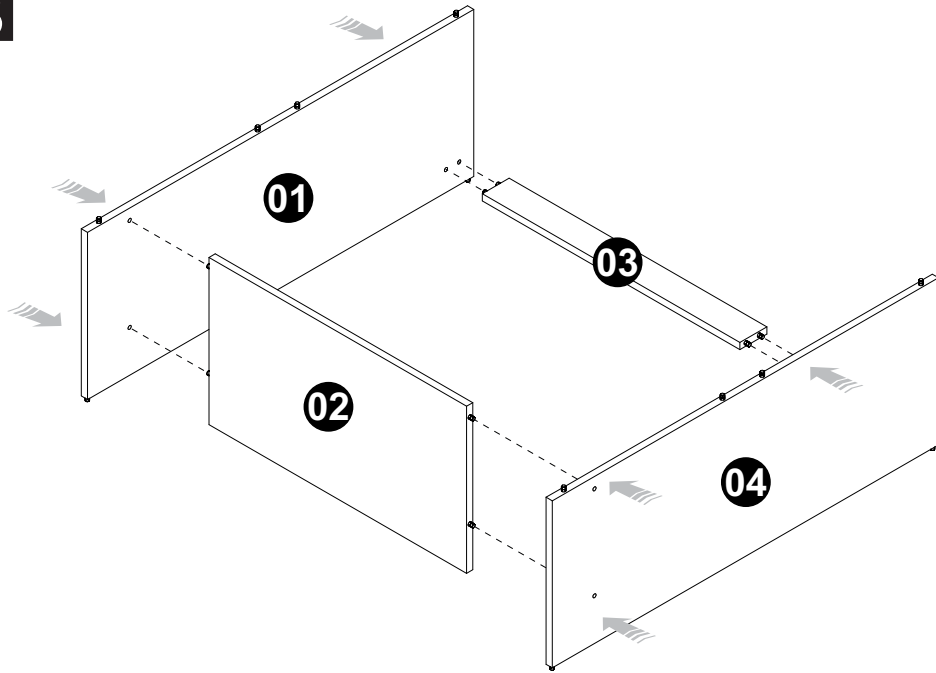

4

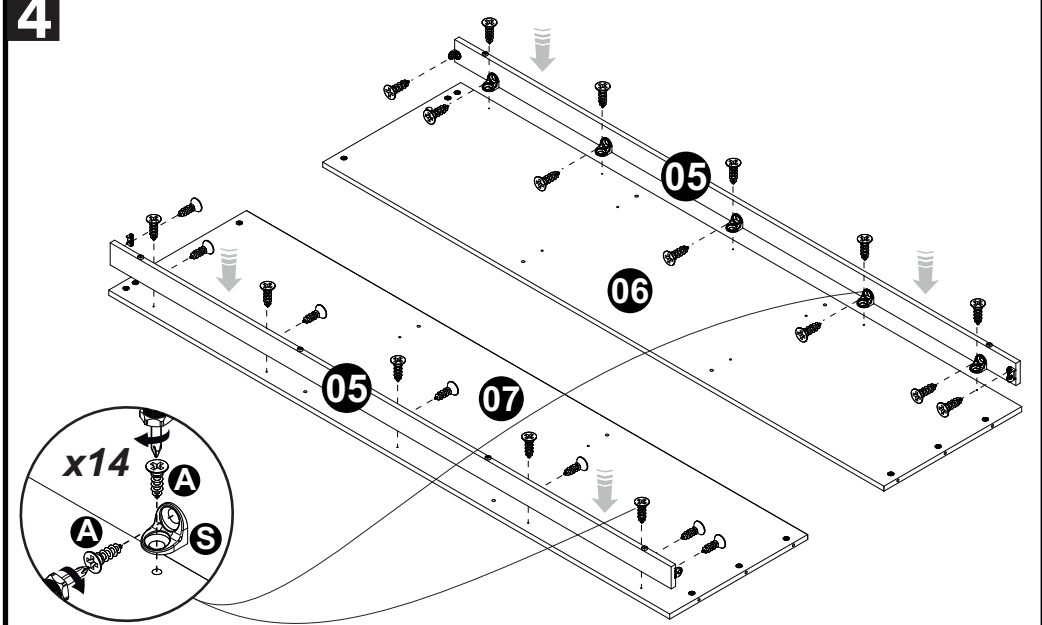

5

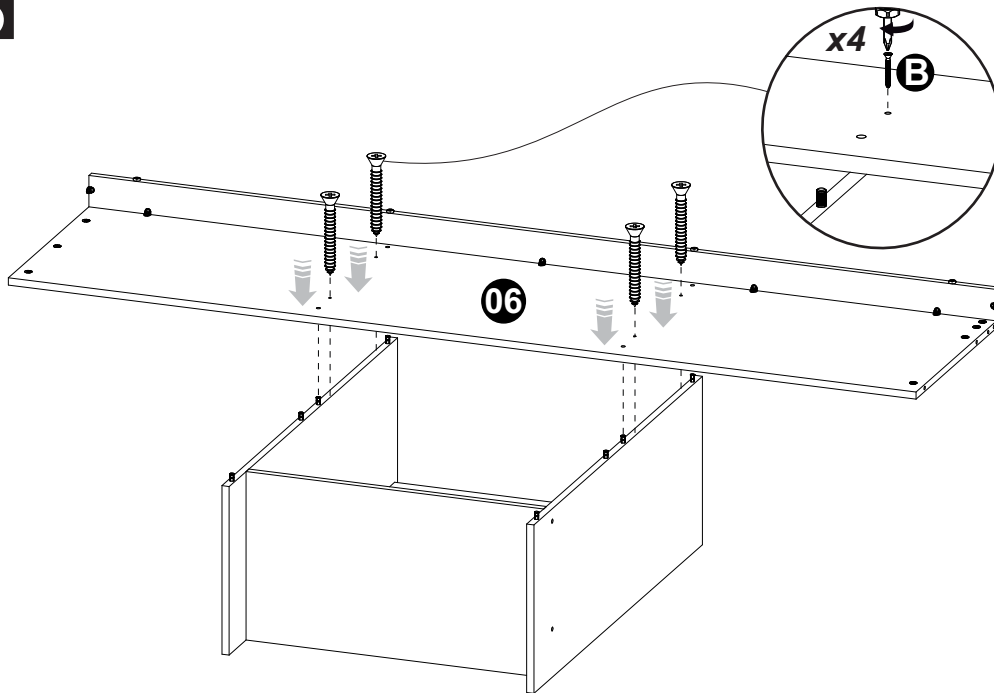

6

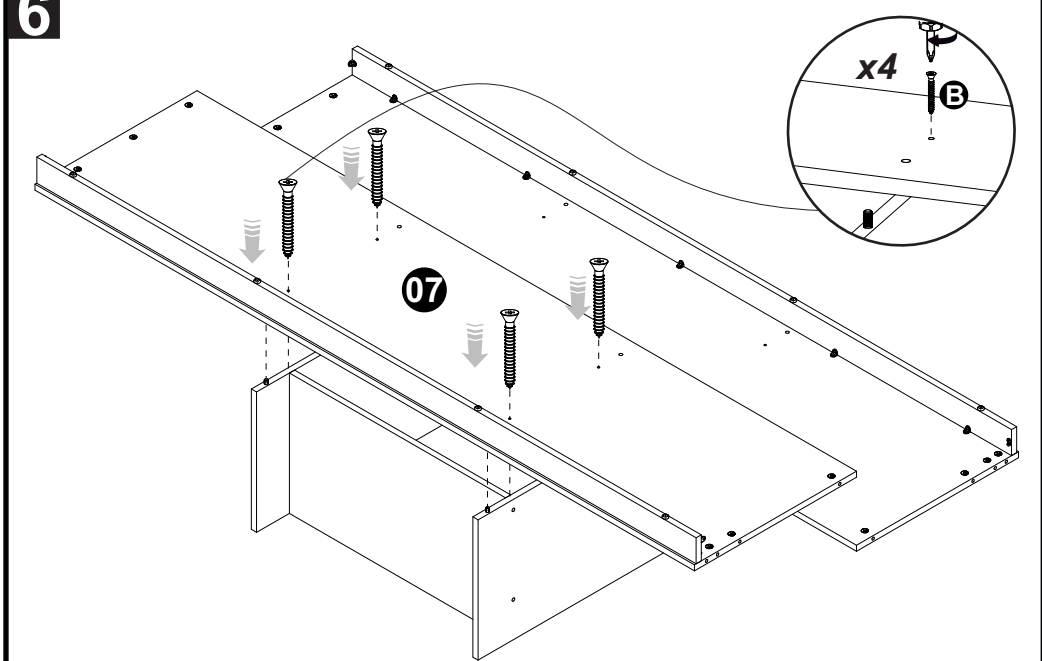

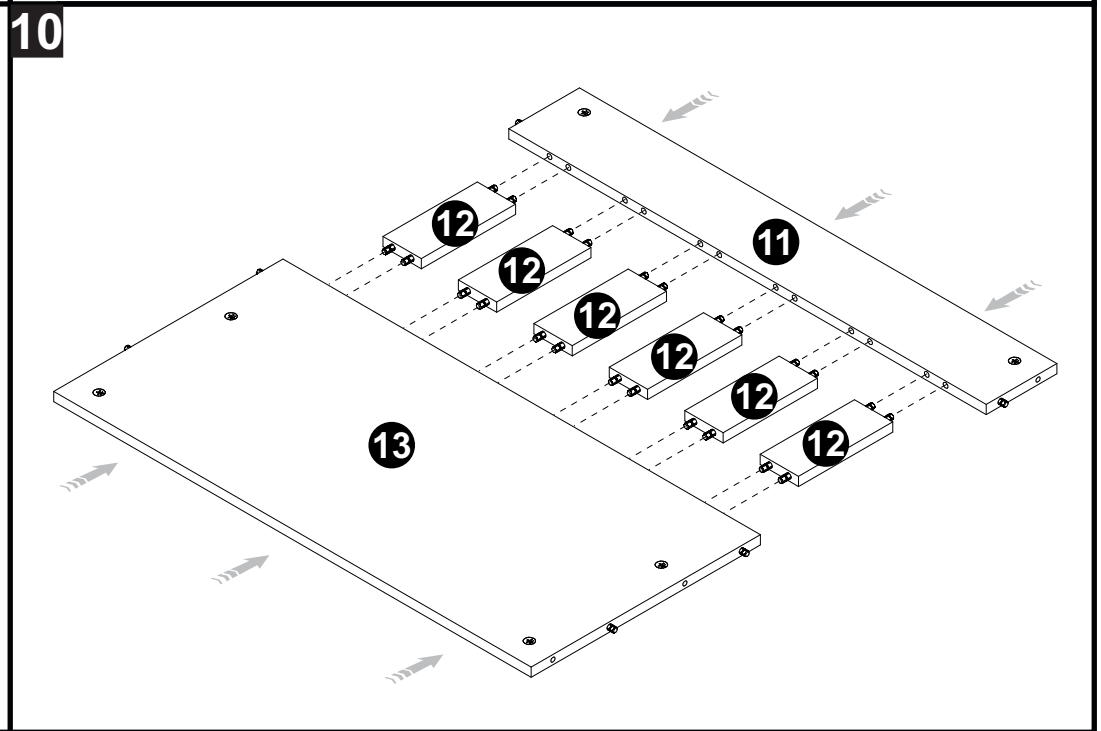
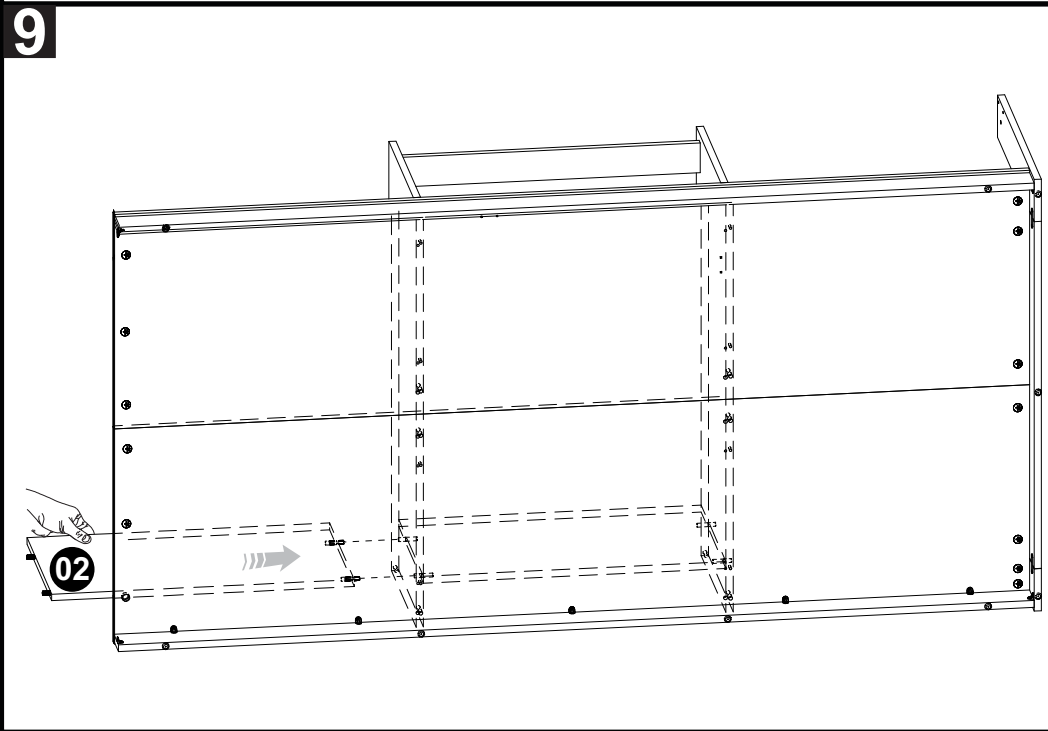
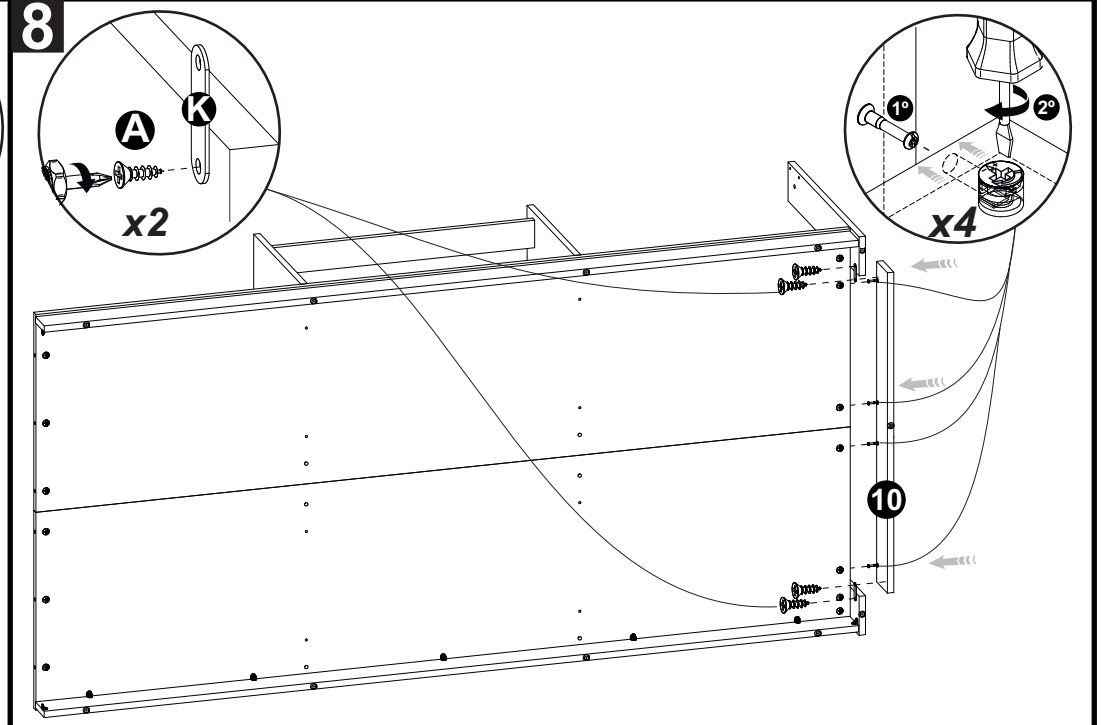
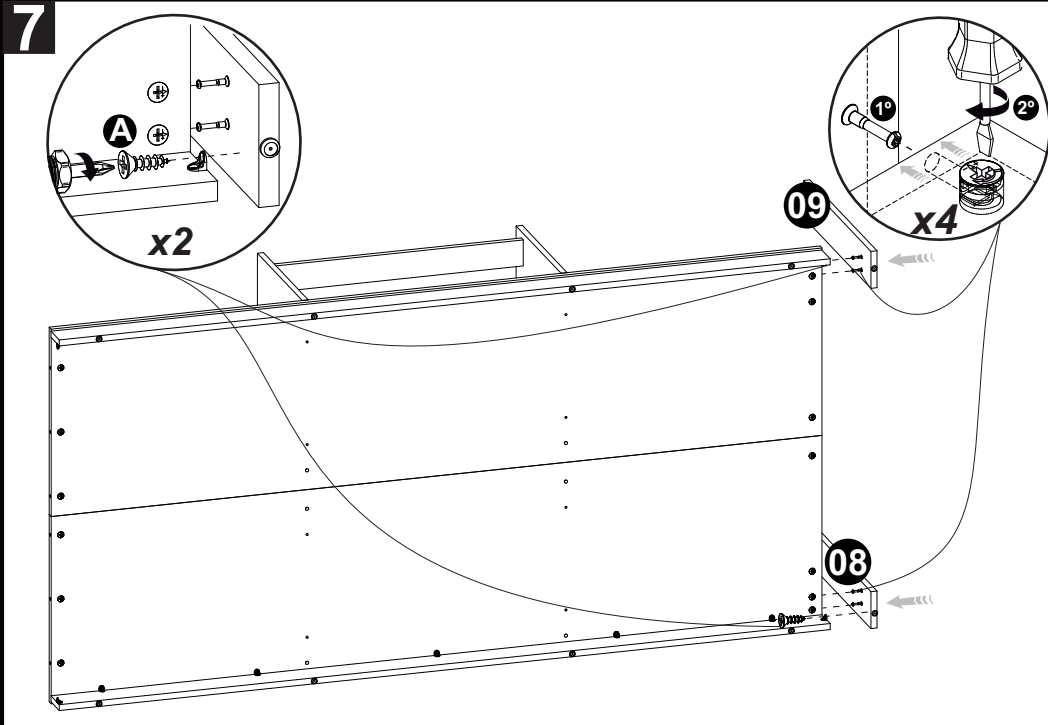

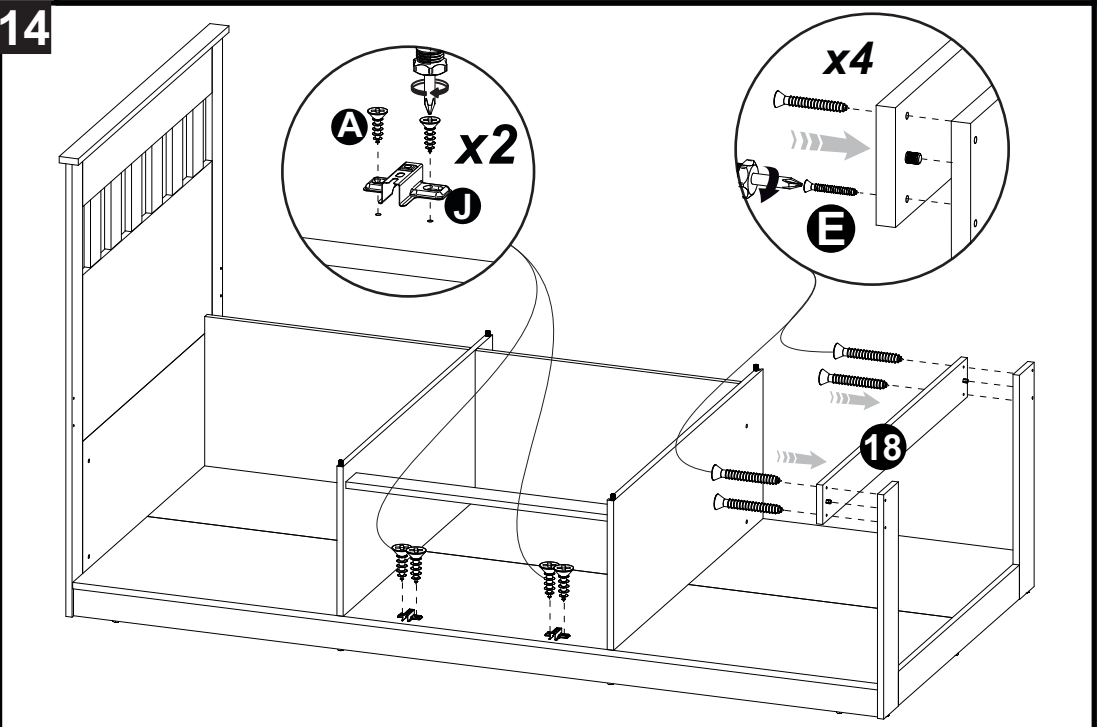
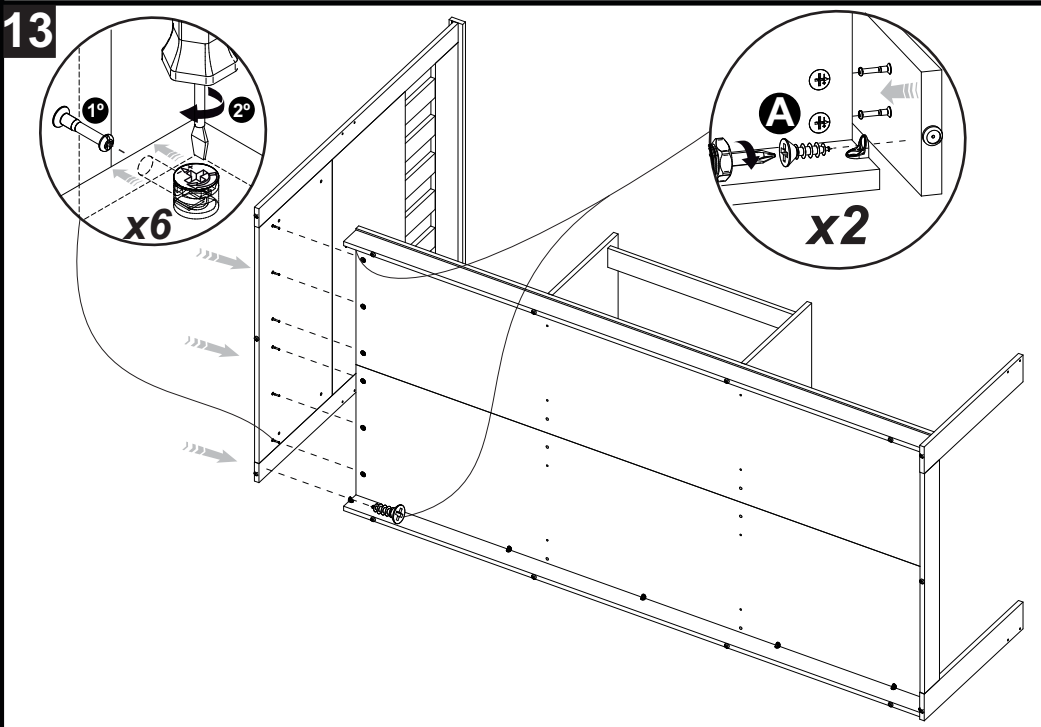
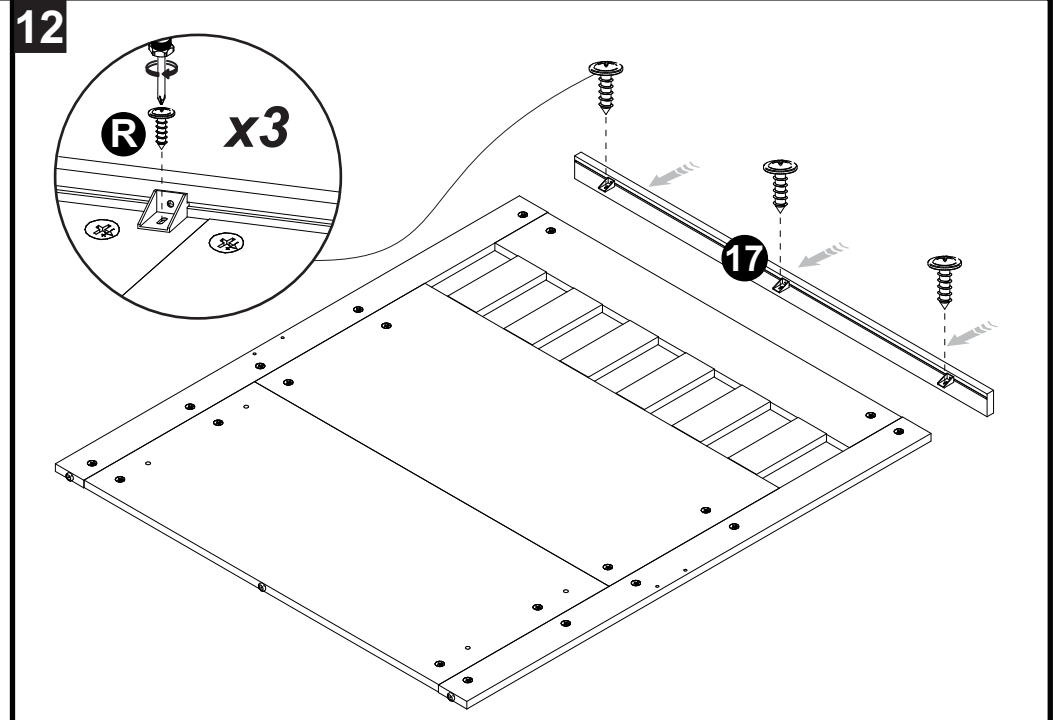
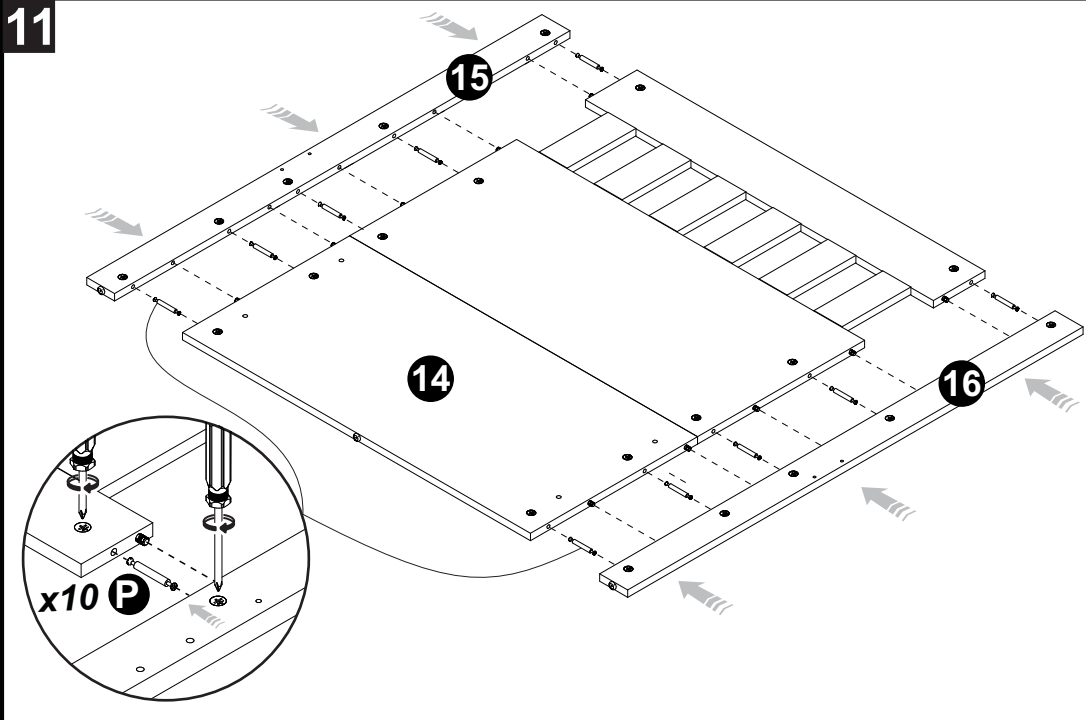

15

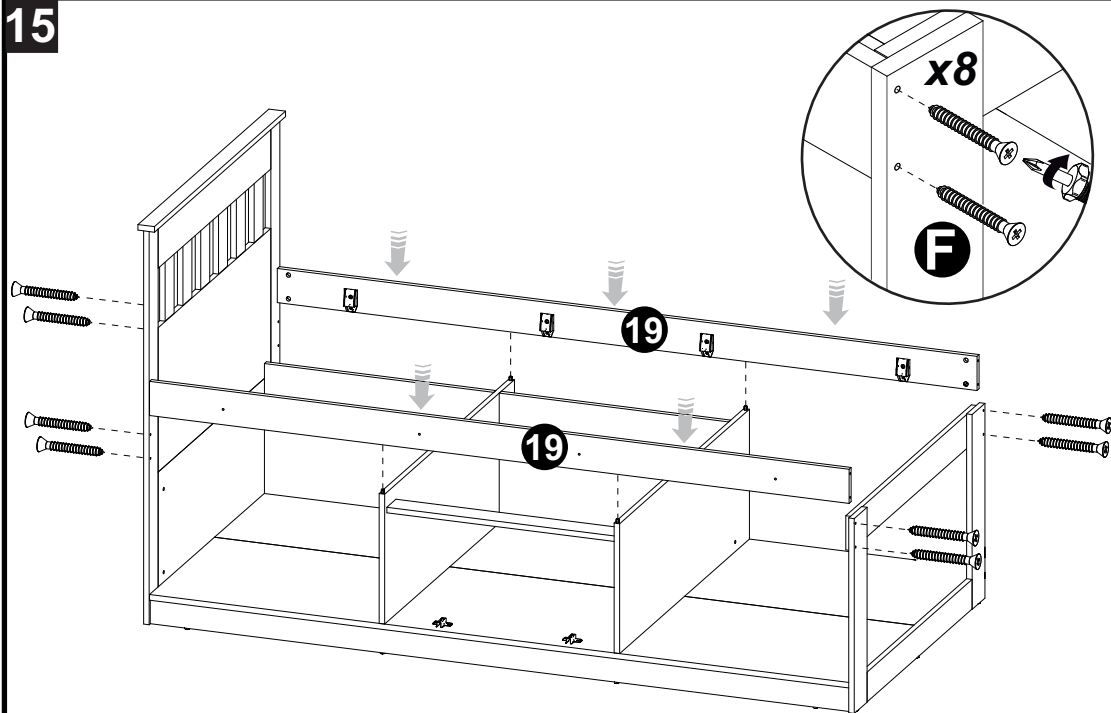

16

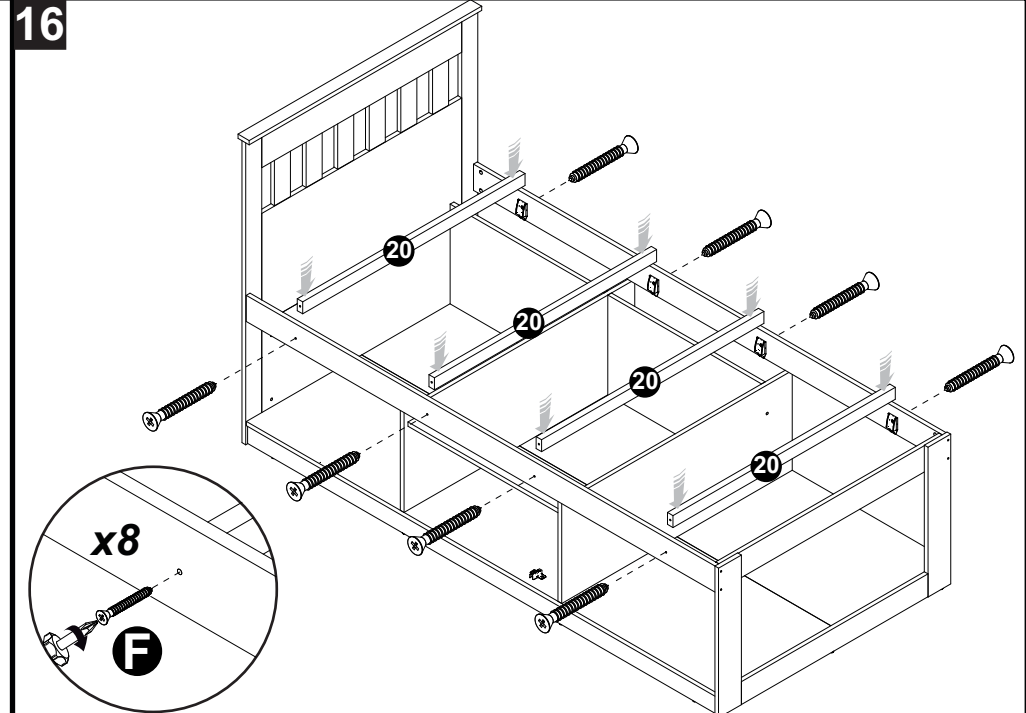

17

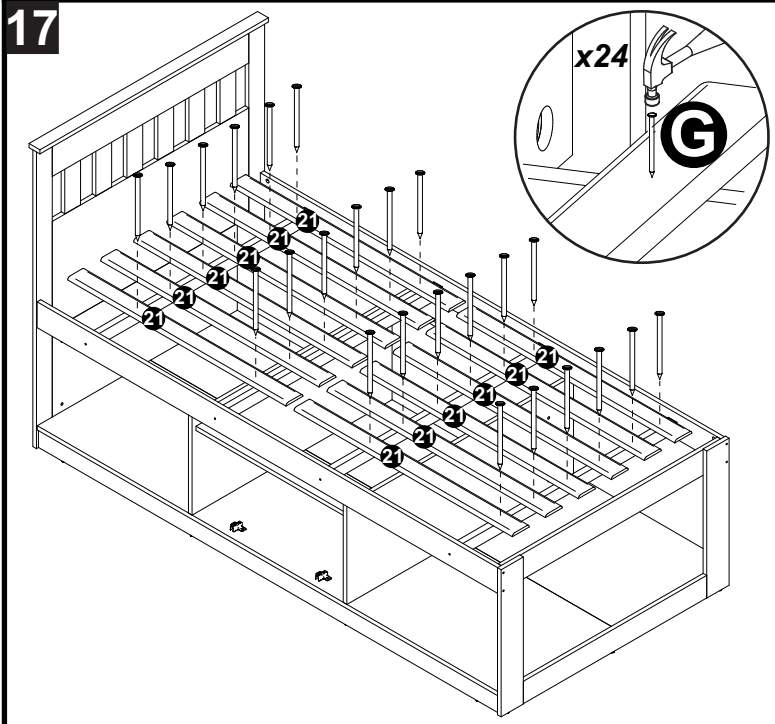

18

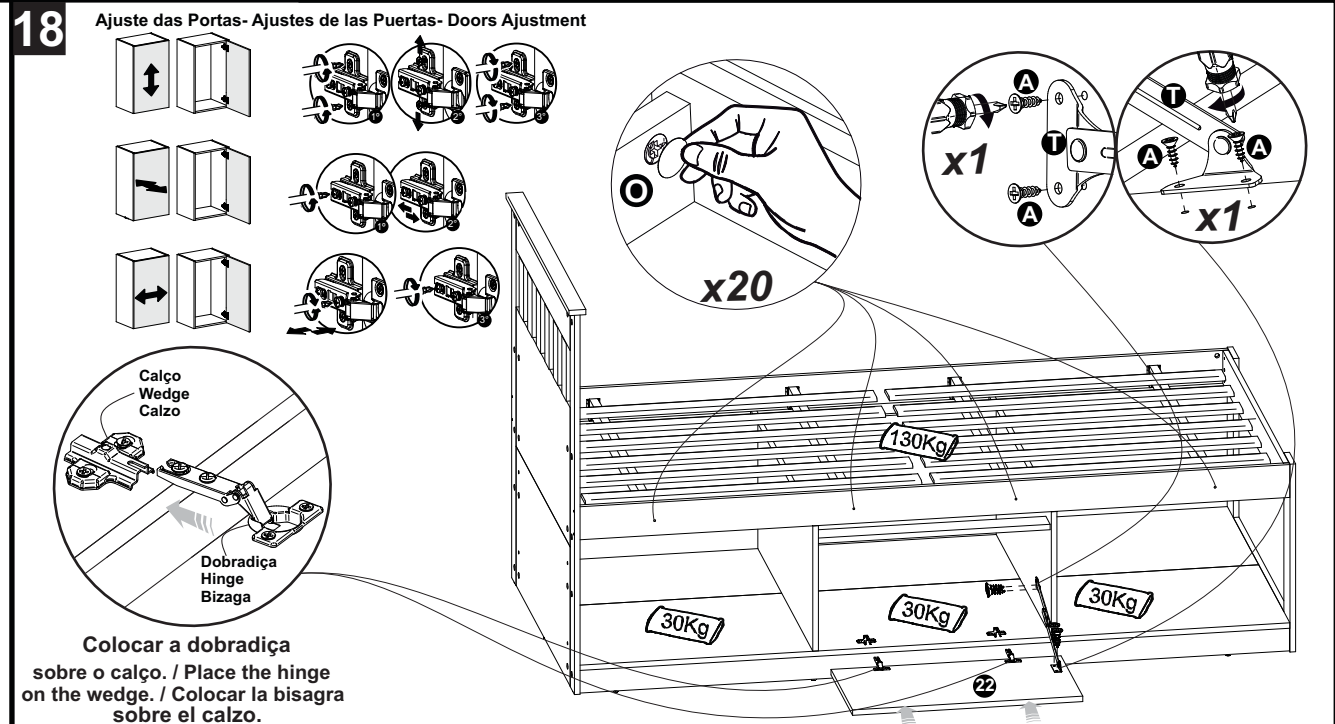

19

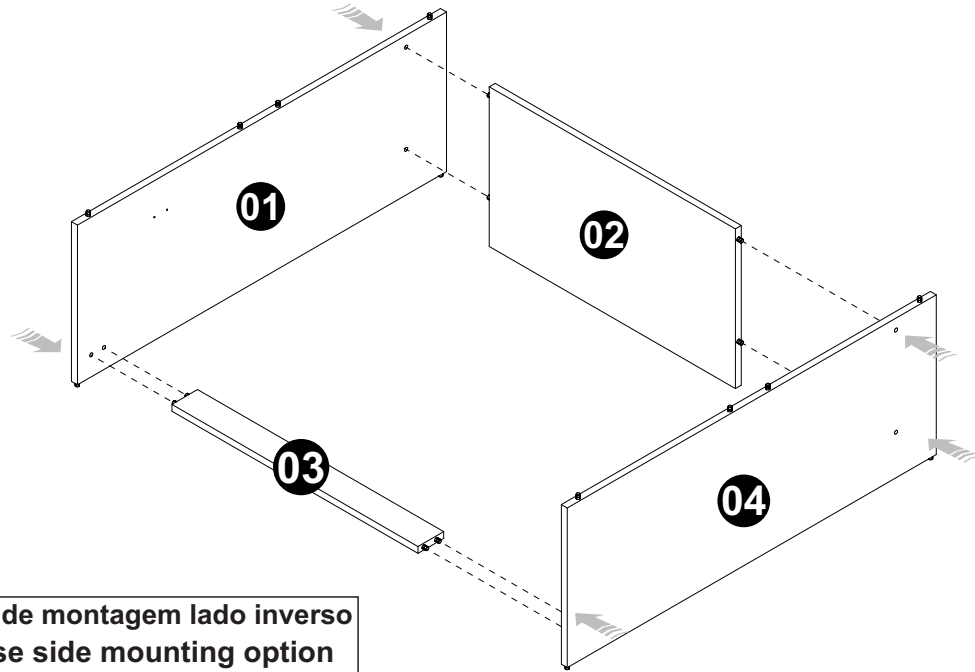

Opção de montagem lado inverso
 Reverse side mounting option
 Opcion de montaje en el reverso

20

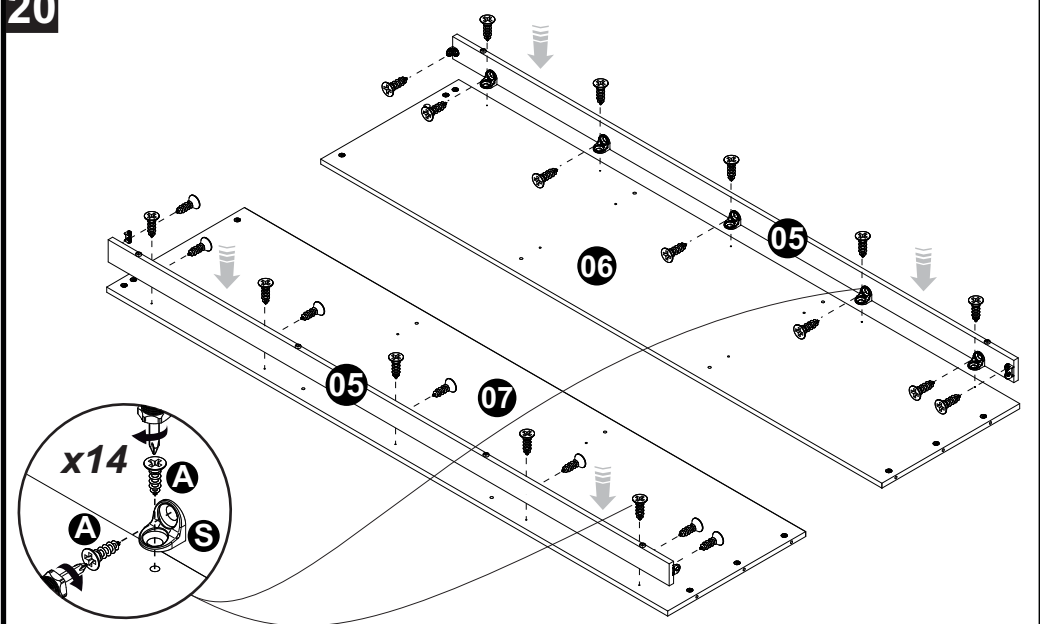

21

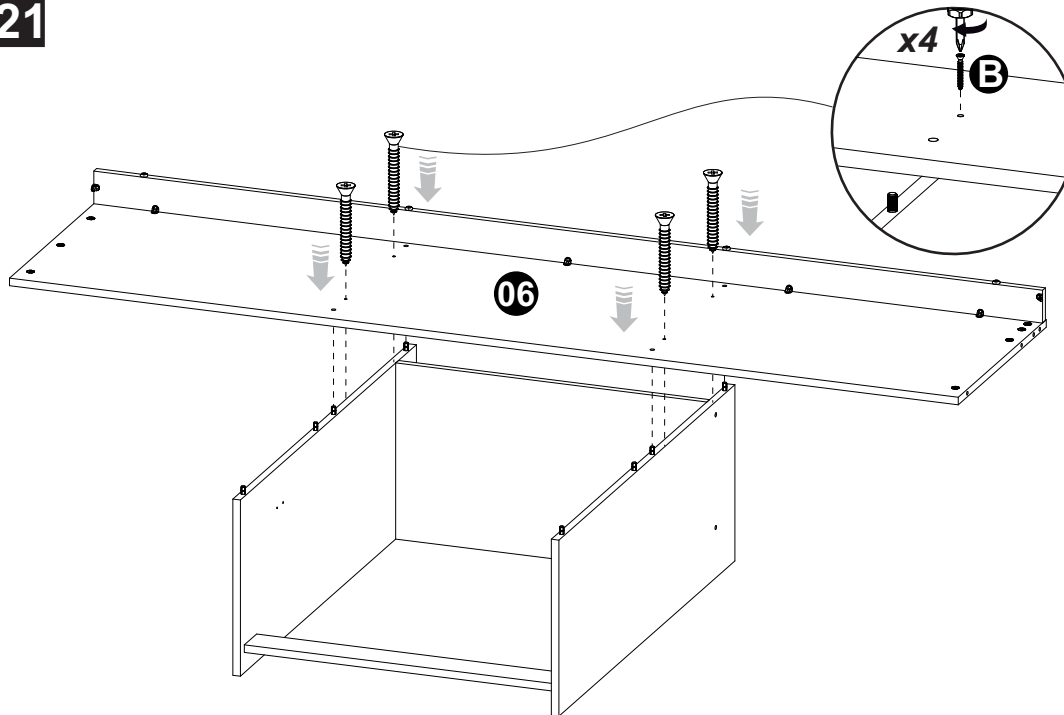

22

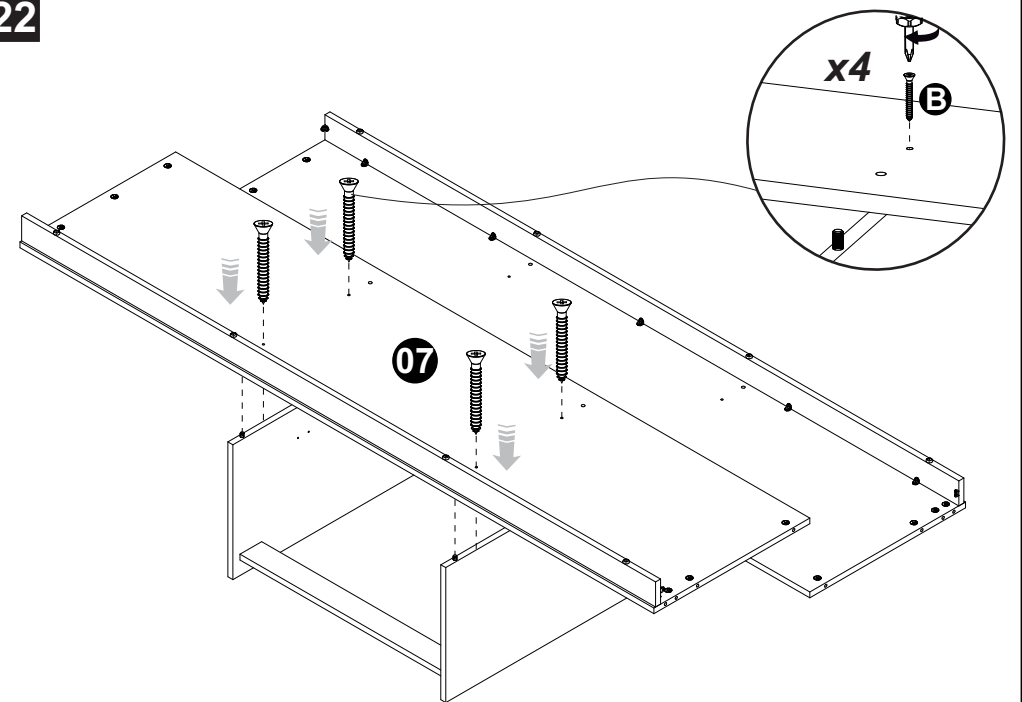

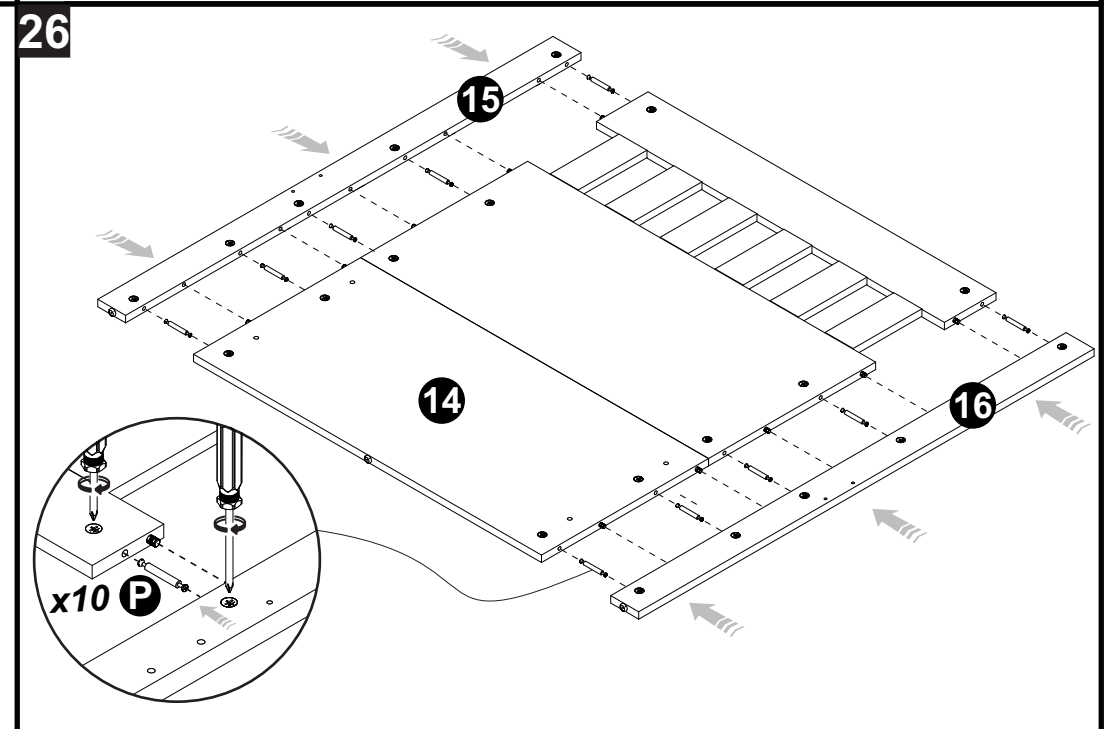
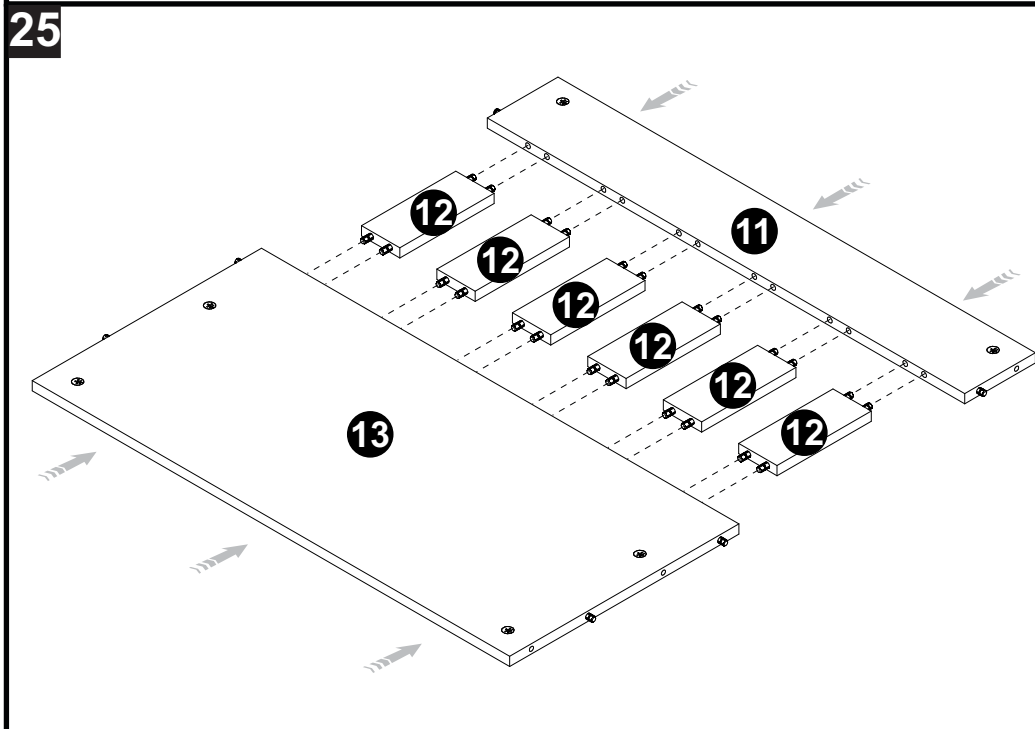
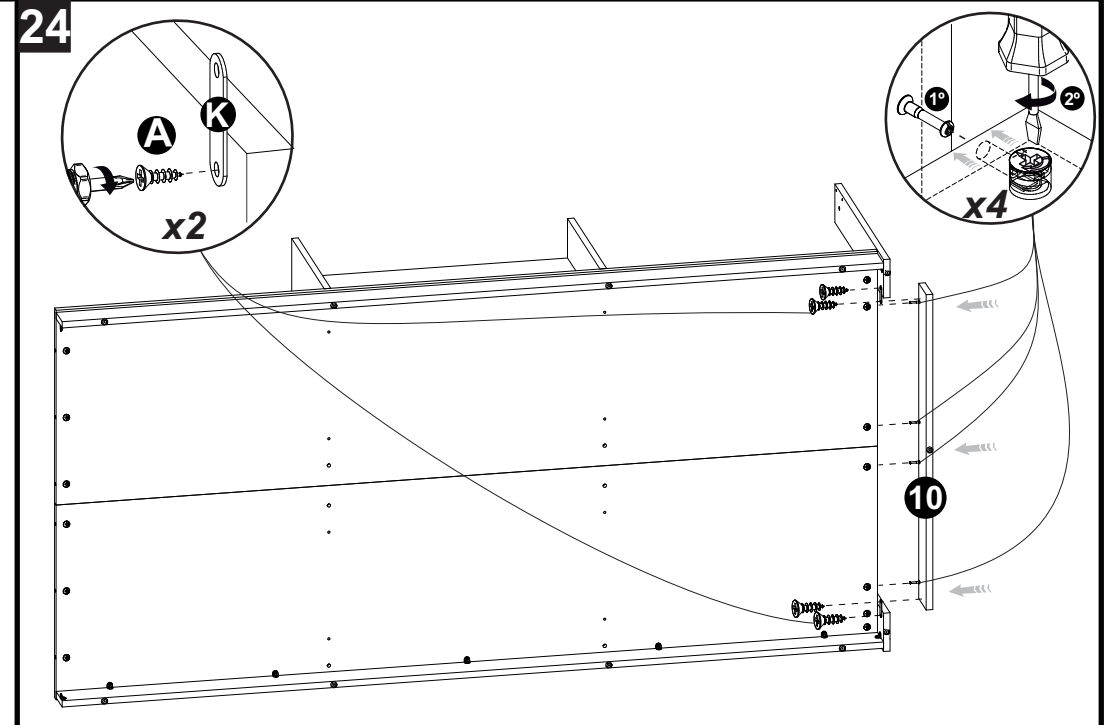
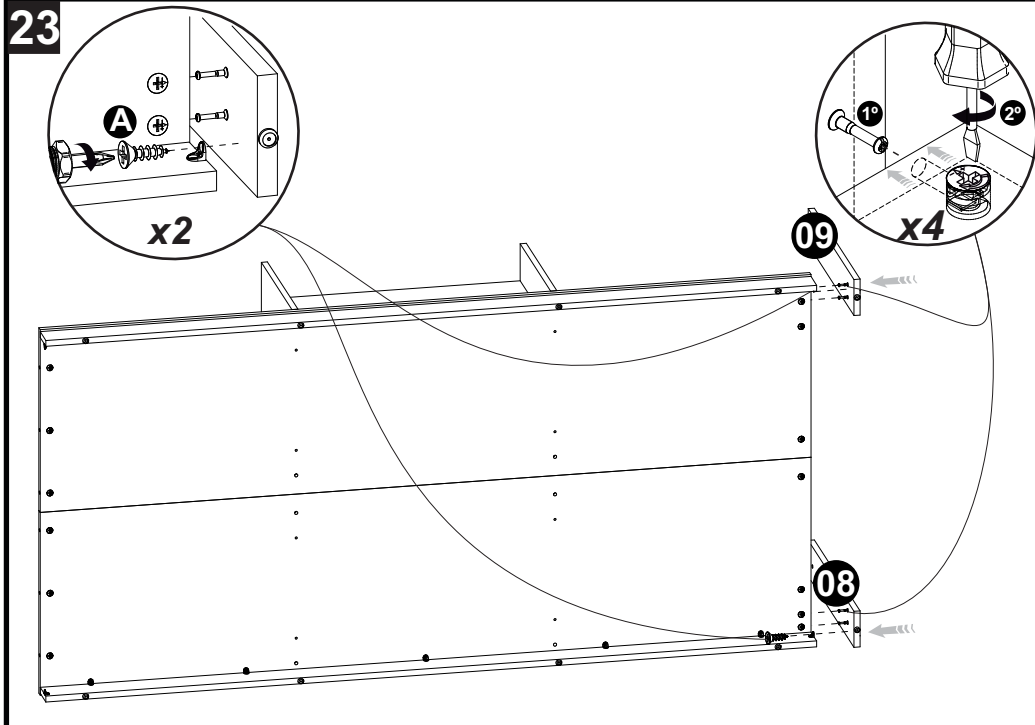

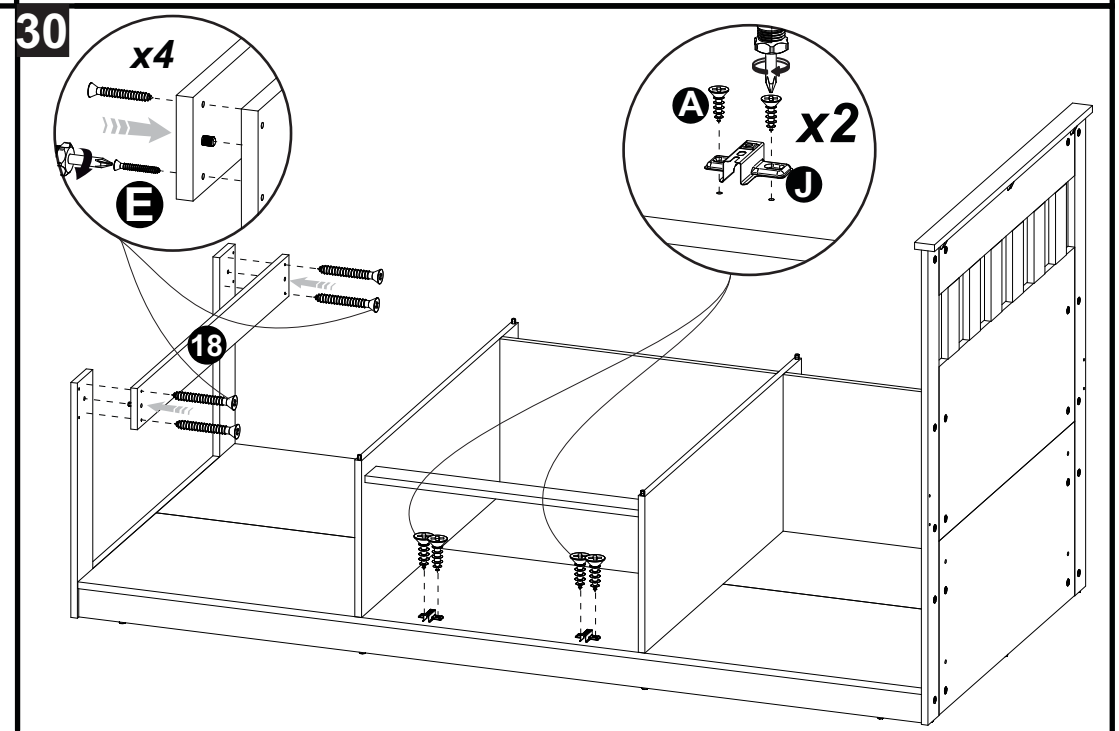
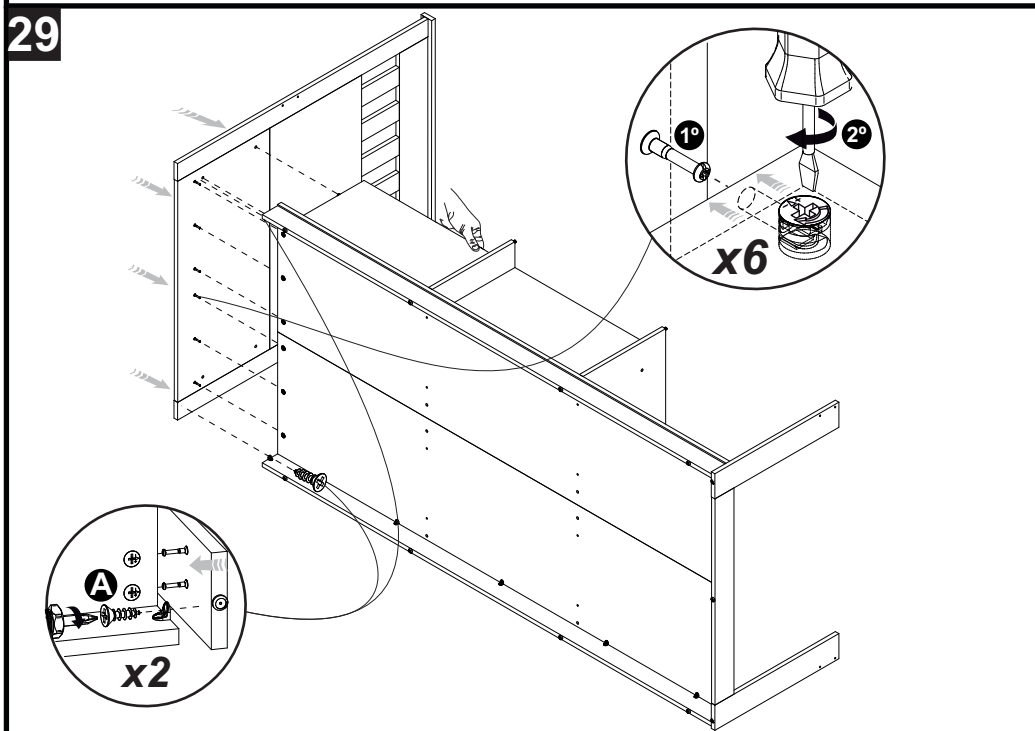
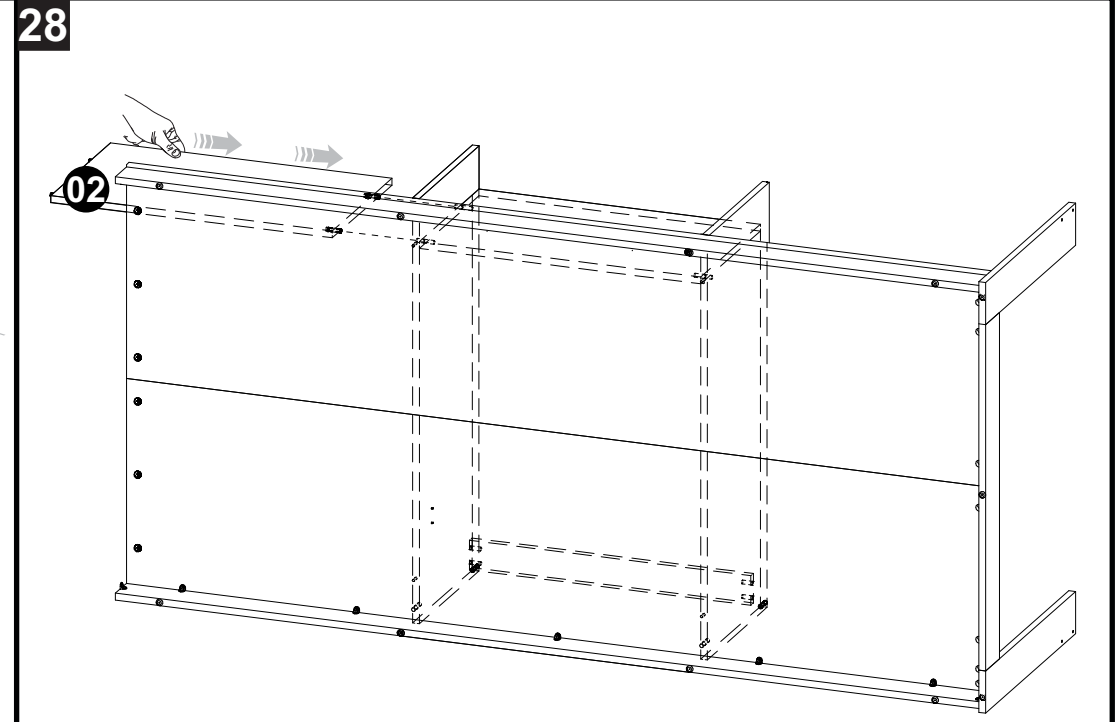
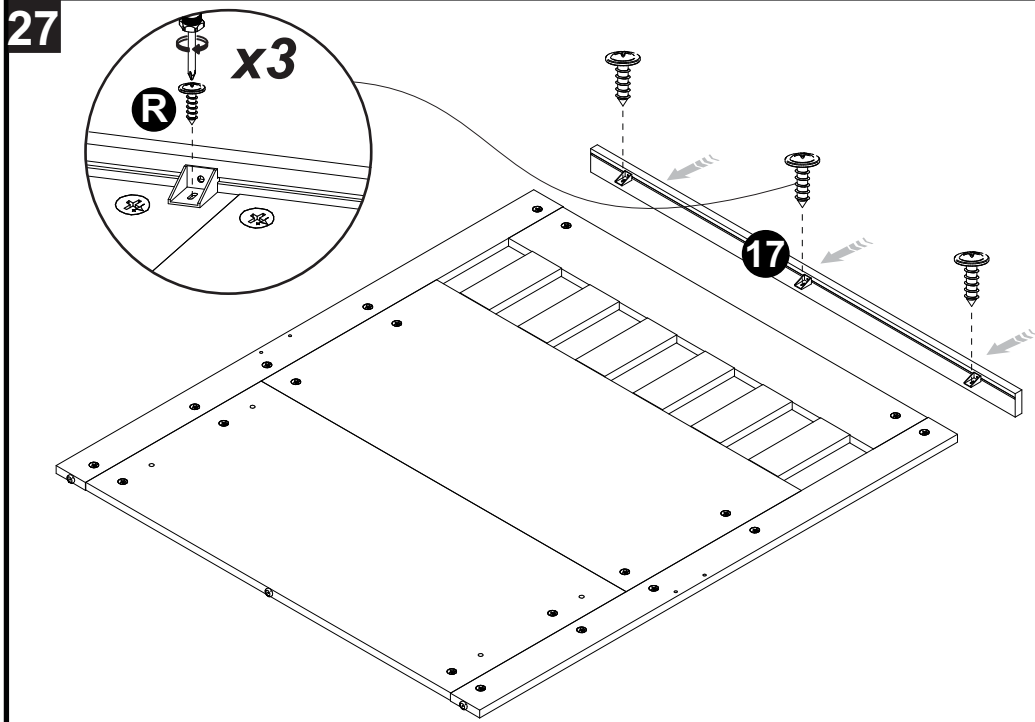

31

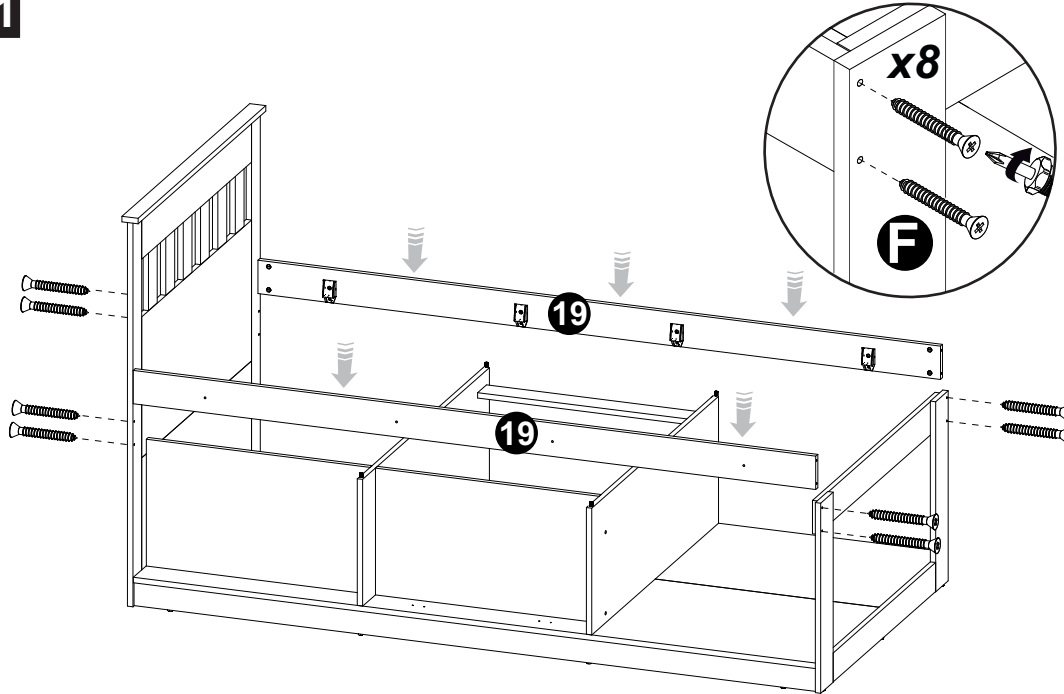

32

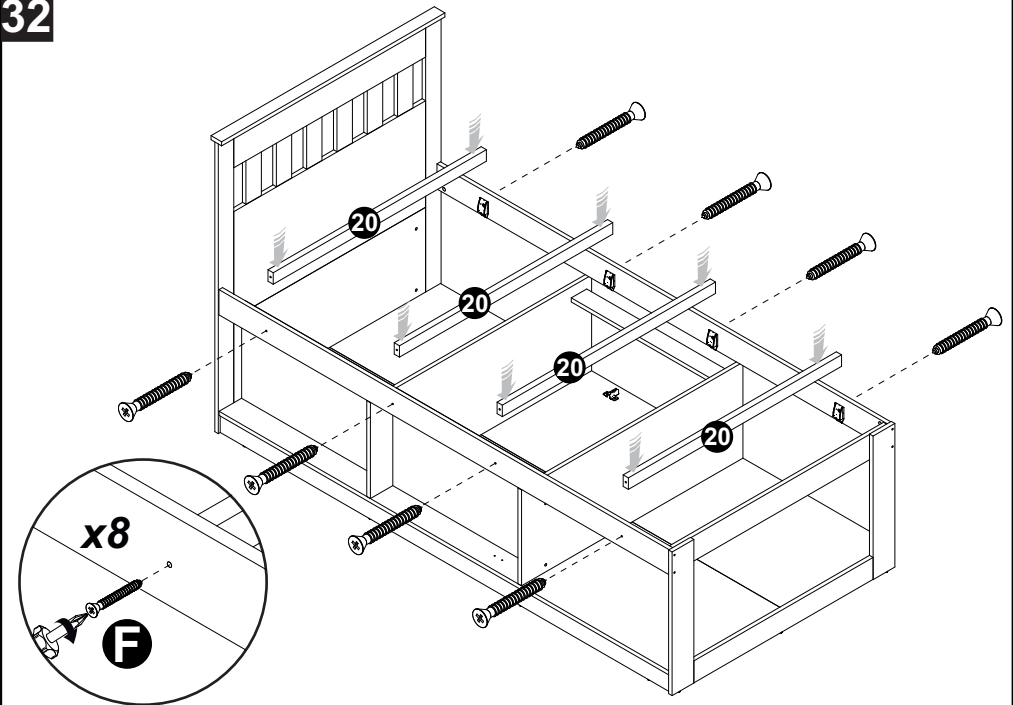

33

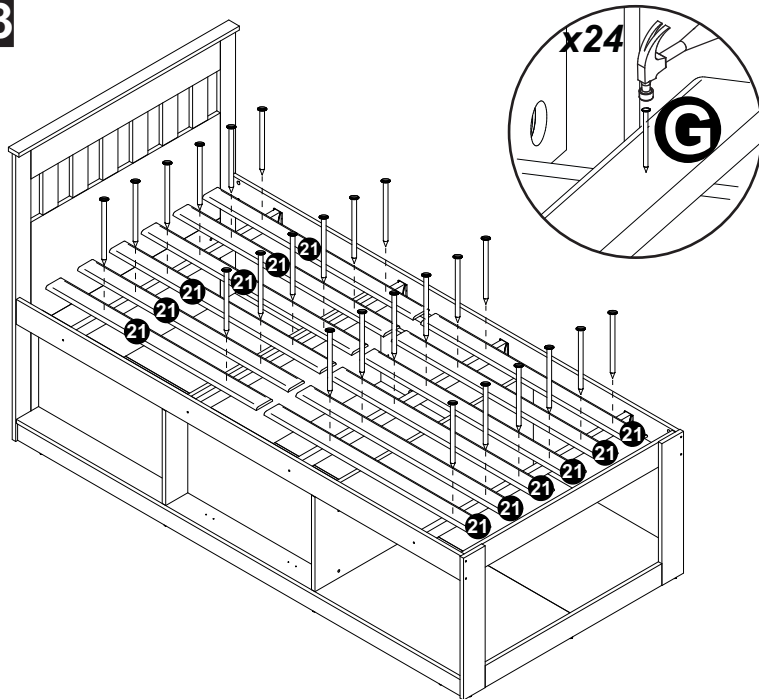

34

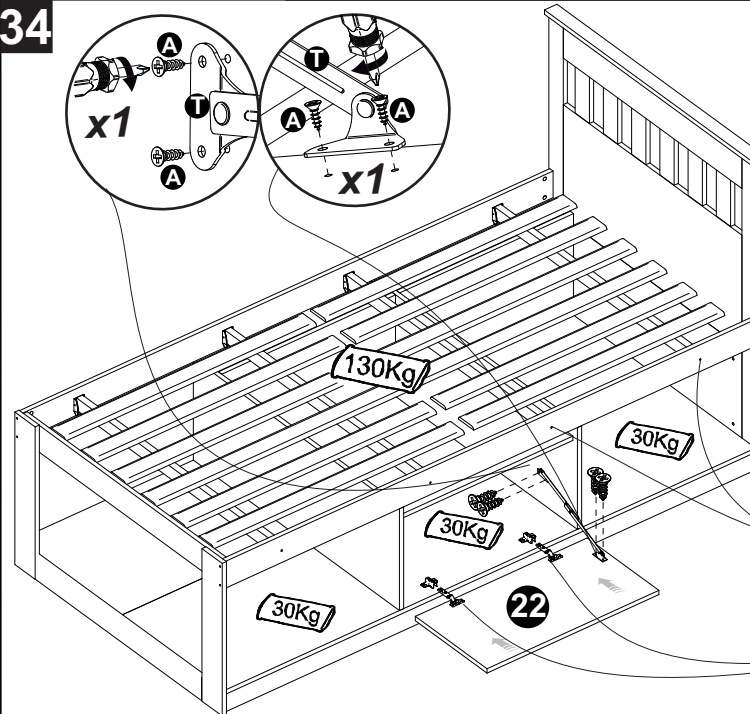

Ajuste das Portas- Ajustes de las Puertas- Doors Ajustment

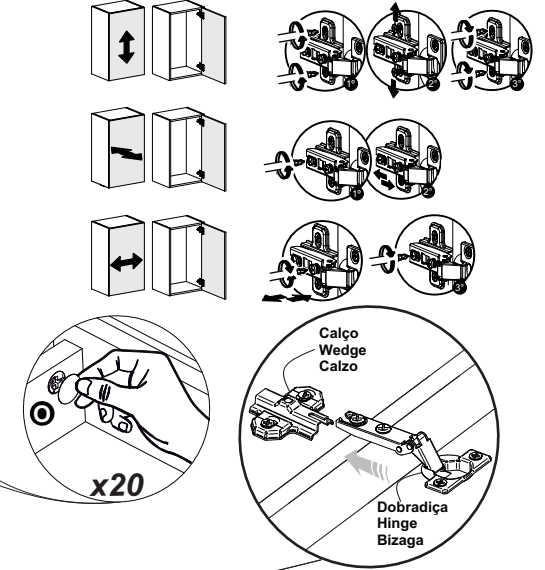

Colocar a dobradiça sobre o calço. / Place the hinge on the wedge. / Colocar la bisagra sobre el calzo.